

RO 280V NW100 HEAVY DUTY WITH GRATING is unique Full Flow Floor Trap with the following features:

- Manufactured from Stainless Steel 304 to ensure acid corrosion and stain resistance.
- A double water seal to ensure odour-free operation.
- Smooth surfaces for easy cleaning, minimum dirt collection and high flow rates.
- A large sludge box which retains all the coarse slurry.
- Easy to dismantle.
- The discharge pipe is fully accessible once the drain has been dismantled.
- Grating Frame Type: Square
- Top Cover Plate Type: Circular aperture / Slots / Holes – as requested
- ❖ Flow Rate 4.5 l/sec
- ❖ Load Capacity 2500 kg
- ❖ Outlet position Bottom Vertical
- ❖ Outlet pipe Outside Diameter 104mm / 110mm as requested
- Typical applications: Wherever there is a need for Higher Load Capacity – General Food Processing, Wine, Beverage, Dairy, Packaging etc. industries

NOTE: Floor finish to be specified

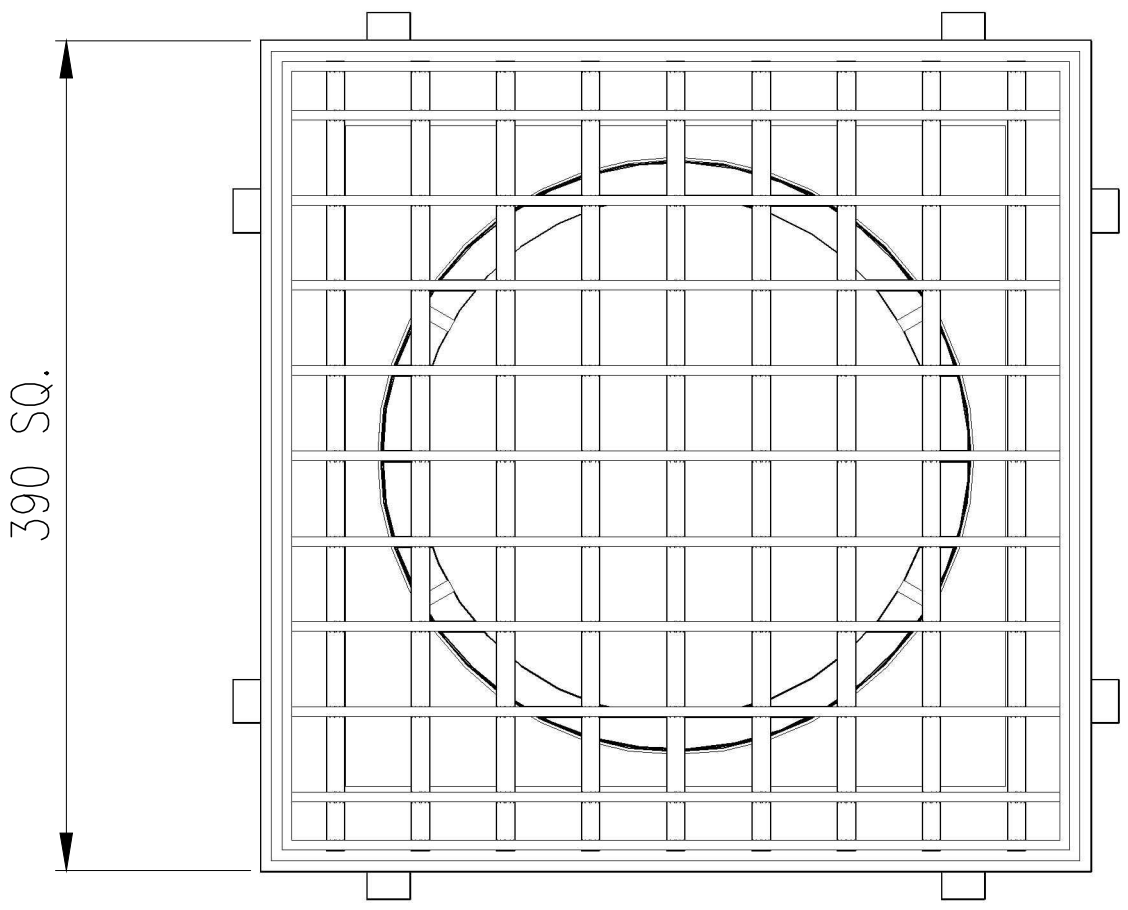

SQUARE FLANGE FOR TILED FLOORS

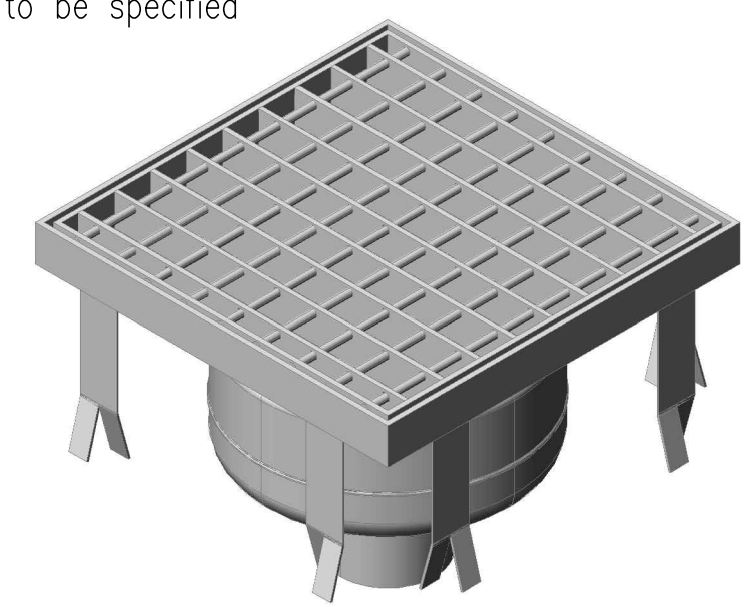

RO 280V NW100 HEAVY DUTY WITH GRATING