

## FAB28RVE1

### 50's Retro style

50's style Refrigerator,  
Lime green, Right hand hinge  
Energy Efficiency Class A++

EAN13: 8017709158286

Total gross volume 256 lt

#### REFRIGERATOR:

Net capacity 222 lt

Dynamic cooling (fan inside)

Adjustable thermostat

Automatic defrost

3 adjustable glass shelves

1 fixed glass shelf

1 chrome wine rack

1 fruit/vegetable drawer

Hidden evaporator

Interior light

#### INNER DOOR:

1 bottle balcony

2 balconies with metallic frame and plastic retainer

1 balcony with double flap

1 egg tray

#### FREEZER

\*\*\*\*

Net capacity 26 lt

1 ice cube tray

#### PERFORMANCE

Nominal power: 90W

Energy consumption: 180 kWh/year

Climatic class: T

Freezing capacity: 2 kg/24h

Rising time: 12h

Noise level: 40 dB(A)

Obstruction with 90° open door: 78 cm (including handle)



## Versions

---

- **FAB28LVE1** - Lime green, hinges on the left
- **FAB28RAZ1** - Pastel blue, hinges on the right
- **FAB28LAZ1** - Pastel blue, hinges on the left
- **FAB28RB1** - White, hinges on the right
- **FAB28LB1** - White, hinges on the left
- **FAB28RBL1** - Blue, hinges on the right
- **FAB28LBL1** - Blue, hinges on the left
- **FAB28RBV3** - Black velvet, hinges on the right
- **FAB28LBV3** - Black velvet, hinges on the left
- **FAB28RCS1** - Colour stripe, hinges on the right
- **FAB28LCS1** - Colour stripe, hinges on the left
- **FAB28RG1** - Yellow, hinges on the right
- **FAB28LG1** - Yellow, hinges on the left
- **FAB28RIT1** - Italian Flag, hinges on the right
- **FAB28LIT1** - Italian Flag, hinges on the left
- **FAB28RNE1** - Black, hinges on the right
- **FAB28LNE1** - Black, hinges on the left
- **FAB28RO1** - Orange, hinges on the right
- **FAB28LO1** - Orange, hinges on the left
- **FAB28RP1** - Cream, hinges on the right
- **FAB28LP1** - Cream, hinges on the left
- **FAB28RR1** - Red, hinges on the right
- **FAB28LR1** - Red, hinges on the left
- **FAB28RRO1** - Pink, hinges on the right
- **FAB28LRO1** - Pastel blue, hinges on the left
- **FAB28RUJ1** - Union Jack, hinges on the right
- **FAB28LUJ1** - Union Jack, hinges on the left
- **FAB28RV1** - Pastel green, hinges on the right
- **FAB28LV1** - Pastel green, hinges on the left
- **FAB28RX1** - Silver, hinges on the right
- **FAB28LX1** - Silver, hinges on the left



# FAB28RVE1

50's Retro style  
fridge  
free standing  
50's retro style  
lime green  
60 cm  
energy rating A++

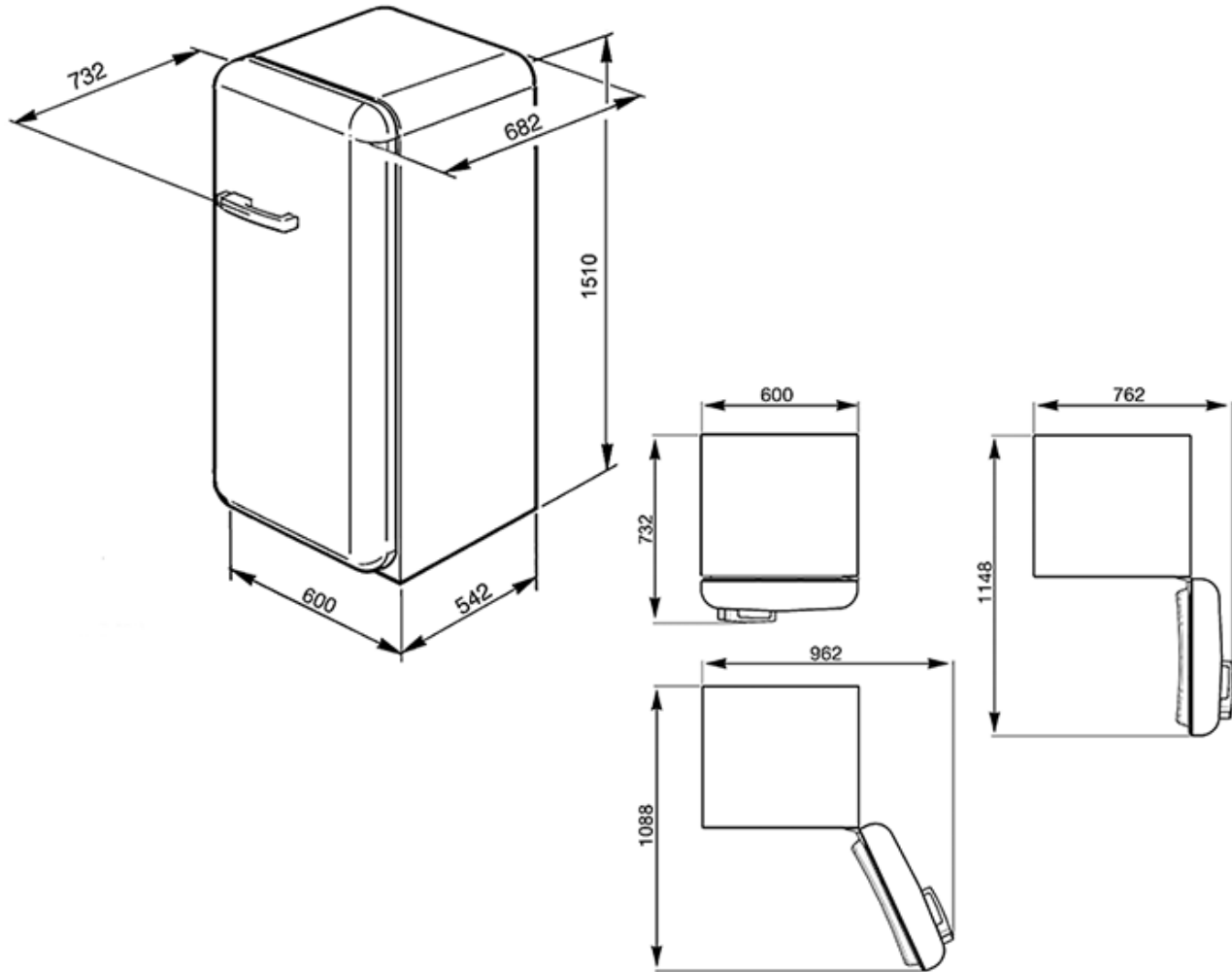

Smeg S.p.A.  
Via Leonardo da Vinci, 4  
42016 Guastalla (RE)  
Tel. 0522 821 1