



CONTRACTING SOLUTIONS
2014-2015

Smeg: redefining architecture in domestic appliances

What makes Smeg truly unique is their revolutionary view of domestic appliances as working pieces of art. This marriage of form and function is evident in Smeg's collaboration with leading architects. Design visionaries such as Guido Canali, Renzo Piano and Mario Bellini have all breathed life into Smeg appliances, sculpting architectural masterpieces for kitchens all over the world. Each of these experts has contributed succinctly to the Smeg way – Technology with Style – creating luxury distinctive appliances that express unique style by perfectly combining design, superior performance and attention to detail.

The elegance of these creations is perfectly complimented by ergonomics and performance, using the latest developments in technology to craft appliances that are truly ground-breaking and environmentally sustainable. Smeg kitchen solutions are the epitome of design, ergonomics and functionality, allowing people to fall in love with their kitchens over and over again.



The Smeg headquarters designed by Guido Canali



Contracting Solutions

This collection of appliances has been specially selected for suitability in the contracting market. These products combine elegance and advanced technology to provide style and reliability, satisfying the needs of the most discerning customer. With cooking, laundry, dishwashing, refrigeration and sinks, this catalogue Selection offers the contract buyer a complete kitchen portfolio.

Designers, architects, specifiers and kitchen specialists can now visit www.smeg.co.za for easily downloadable design resources such as technical drawings and 3D files of all Smeg appliances perfect for use when planning new kitchens.





smeg
technology with style



Timeless design. Made to be efficient.



MADE IN ITALY
PREMIUM QUALITY AND DESIGN

www.smeg.co.za

OVER 65 YEARS OF MADE IN ITALY

Founded in 1948 by the longest standing Italian family in the production of cooking appliances, **Smeg** is now the only appliance company with PRODUCTION EXCLUSIVELY IN ITALY. The company name, in Italian, is an acronym of: **S**malterie **M**etallurgiche **E**miliane **G**uastalla (in English it translates as “Metal Enamelling Factory based in Guastalla, Emilia”).



Emilia Region is known as the food valley of Italy and the home of technology and design.

Smeg Architects

What makes Smeg truly unique is their revolutionary view of domestic appliances as working pieces of art. This marriage of form and function is evident in Smeg’s collaboration with leading architects in the creation of their kitchen solutions. Design visionaries such as **Guido Canali, Renzo Piano, Mario Bellini** and more recently, **Giancarlo Piretti**, have all breathed life into Smeg appliances, sculpting architectural masterpieces for kitchens all over the world.

Each of these experts has contributed succinctly to the Smeg way - Technology with Style - creating luxury distinctive appliances that express unique style by perfectly combining design, superior performance and attention to detail.

Contents

60cm Built-In Solutions - Classic	6
70cm Built-In Solutions - Classic	8
90cm Built-In Solutions - Classic	9
60cm and 70cm Built-In Solutions - Linea	10
Domino Hobs - Classic and Linea	12
Linea and Classic Compact Range	13
Opera Freestanding Cookers and Extractors	14
Victoria Freestanding Cookers and Extractors	15
Symphony Freestanding Cookers and Extractors	16
Symphony and Concert Freestanding Cookers and Extractors	17
Dishwashers	18
Laundry	19
Freestanding Refrigeration	20
FAB Refrigeration	21
Domestic Pro-line	22
Sinks And Bowls	23
Technical Drawings	24

60CM BUILT-IN SOLUTIONS - CLASSIC

KSEC6S

60CM VISOR EXTRACTOR
SILVER



Standard Visor
Slider Switches
240 m3/h Ducted
69dB Noise Level

KSEG5X

50CM INTEGRATED EXTRACTOR
STAINLESS STEEL



580m3/h Ducted
69Db(A) Noise level on 3rd speed
Vent 125mm
Optional: KITFC142 Charcoal filter for re-circulation

KSA600HX

60CM WALL EXTRACTOR
STAINLESS STEEL



4 Speed
650 m3/h
65 Db(A) on 3rd speed
Vent 150mm
Optional: KITKSA charcoal filter for recirculation

SE60D

60CM CERAMIC NCP HOB
STRAIGHT EDGE

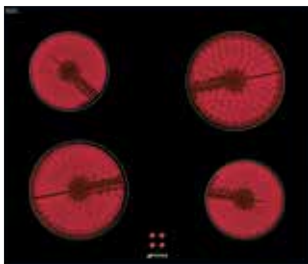

4 high-light radiant zones
"Suprema" black ceramic glass
Residual heat indicators
Nominal power 6000 W
Must be installed with OVEN: SF0351X

PS60GHC

60CM GAS HOB
STAINLESS STEEL



4 Gas Burners
Electric Ignition
Flame Failure Safety
Cast Iron Grids
Adaptable for LPG Gas or Natural gas



SER60SGH3
Stainless Steel

SE2640TD2

60CM CERAMIC HOB
ANGLED EDGE GLASS

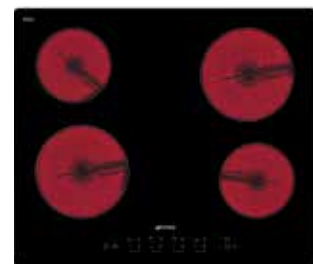

4 high-light radiant zones
"Suprema" ceramic glass
Residual heat indicators
Touch Control
Auto Safety Cut-out

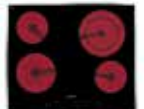

SE2641CX2
Straight Edge

SF0351X

60CM ELECTRIC OVEN
UNDER COUNTER



4 Function Static
63 lt.Net Oven Capacity
Vapor Clean Function
Easy Clean Enamel
Metal side racks
Removable internal glass for cleaning
Must be installed with HOB: SE60D

SF381X

60CM ELECTRIC OVEN
STAINLESS STEEL



6 Function Ventilated
72 lt.Net Oven Capacity
Easy Clean Enamel
Metal side racks
Removable inner door
Removable internal glass for cleaning

SF390X

60CM ELECTRIC OVEN
STAINLESS STEEL

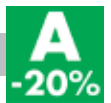

11 Function Thermo-ventilated
72 lt.Net Oven Capacity
Vapor Clean Function
Easy Clean Enamel
Metal side racks
Removable internal glass for cleaning



MI20X-1

60CM BUILT-IN MICROWAVE OVEN
STAINLESS STEEL



21 lt capacity
36 Automatic programs
Stainless steel interior
Microwave Oven
Quartz Grill
Built-in frame

CR330AP

54CM INTEGRATED FRIDGE/FREEZER COMBINATION



311 lt Gross capacity
221 lt. net capacity fridge
67 lt. net capacity freezer
Auto Defrost
4 Glass Adjustable Shelves
Adjustable Thermostat
Reversible Doors

UM45

45CM UNDER MOUNTED BOWL
STAINLESS STEEL



450 x 400mm single bowl
Bowl Depth 180mm
Stainless steel Thickness 0.7mm

STA6445-2

60CM INTEGRATED DISHWASHER



13 Place Setting
5 Programmes
Speed 27min
1/2 Load Flexizone option
Hyclean Sanitizing option
Orbital Plus Washing system
Natural Condenser Drying
45dB Noise level
Water consumption: 9 lt./cycle

LSTA146S

60CM INTEGRATED WASHER DRYER



12 Washing Programmes
6 Drying Programmes
6 kg Washing capacity
4 kg Drying capacity
1400rpm Variable Spin
Condenser dryer
Humidity Sensor

70CM BUILT-IN SOLUTIONS - CLASSIC

KSED75X-1

70CM WALL EXTRACTOR
STAINLESS STEEL



3 Speed
700m³/h Ducted - 73 Db(A) Noise level on 3rd speed
Vent 125mm
Optional: FLT2 Charcoal filter for re-circulation



SE2773CX2

90CM CERAMIC HOB
STAINLESS STEEL EFFECT TRIM



5 Plate easy clean black ceramic glass
3 Norm/1 Dual/1 Giant zone
9 Power levels - Touch control
Auto Safety Cut-out and Individual Timers

SE70SGH-5

70CM GAS HOB
STAINLESS STEEL



5 Gas burners
1 Ultra-rapid Dual burner 5.0 kW
Electric ignition and Flame Failure Safety
Adaptable for LPG Gas or natural gas

SC709X-2

70CM ELECTRIC OVEN
STAINLESS STEEL



10 Function Thermo-ventilated
Electronic Programmer with Min Minder
80lt. Net Oven Capacity
Rotisserie
Removable internal glass for cleaning

A

FME24X-2

60CM BUILT-IN MICROWAVE OVEN
STAINLESS STEEL



24 lt capacity
3 Cooking functions with Quartz Grill
Digital clock with electronic controls
Cook/Defrost Auto functions
5 Power Levels
Pizza function

90CM BUILT-IN SOLUTIONS - CLASSIC

KSA900HX

90CM WALL EXTRACTOR
STAINLESS STEEL



4 Speed
Vent 150mm
650 m3/h - 65 Db(A) on 3rd speed
Optional: KITKSA charcoal filter for recirculation

KSED95X-1

90CM WALL EXTRACTOR
STAINLESS STEEL



3 Speed
Vent 125mm
700m3/h Ducted - 73 Db(A) on 3rd speed
Optional: FLT2 Charcoal filter for re-circulation

KI90C-2

90CM ISLAND EXTRACTOR
STAINLESS STEEL



3 Speed
4 Halogen Lights
Vent 150mm/ 700m3/h Duct
Electronic Push Buttons
63Db(A) Noise level on 3rd speed
Optional: KITFC161 Charcoal filter for re-circulation

SE2951TC2

90CM CERAMIC HOB
BLACK GLASS ANGLED EDGE



5 Plate easy clean black ceramic glass
3 Norm/1 Dual/1 Giant zone
9 Power levels - Touch control
Auto Safety Cut-out and Individual Timers

SE93SGH3

90CM GAS HOB
STAINLESS STEEL



5 Gas Burners
Electric Ignition
Flame Failure Safety
Cast Iron Grids
Wok Pan Stand
Matches Classic and Linea design

PGF95-4

90CM GAS HOB
STAINLESS STEEL



5 Gas Burners
Electric Ignition
Flame Failure Safety
Cast Iron Grids
Wok Pan Stand
Matches Classic and Linea design

SA990XR-8

90CM BY 48CM ELECTRIC OVEN
STAINLESS STEEL



6 Function Thermo-ventilated
Digital Electronic Programmer
Easy Clean Enamel
80lt.Net Oven Capacity
Roof Liner and Metal side racks

FMC30X-2

60CM BUILT-IN MICROWAVE OVEN
STAINLESS STEEL



30 lt capacity
6 Cooking functions with Grill
Digital clock with electronic controls
Cook/Defrost Auto functions
4 Power Levels
Special Duo Steam Function

60CM AND 70CM BUILT-IN SOLUTIONS - LINEA

KAT600HX

60CM WALL EXTRACTOR
STAINLESS STEEL



3 Speed
437m³/h Ducted
50dB Noise Level on 3rd speed
Vent 150mm
Optional: KIT1C Charcoal filter for re-circulation



KAT900HX
Stainless Steel

KSE912X3

90CM WALL EXTRACTOR
STAINLESS STEEL - SILVER GLASS FRONT PANEL



4 Speeds with Soft Touch Electronic Controls
White Digital Display / 900m³/h Ducted
46dB (A) at 1st speed - 70dB (A) at 4th speed
Optional charcoal filter for re-circulation: KITFC161



KSE912BX3
White Glass



KSE912NX3
Black Glass

SI641ID2

60CM INDUCTION HOB
BLACK GLASS



4 Induction Cook Zones
9 Power Levels
Touch Control
Residual Time Indicator
NOTE: Only magnetic based pans/pots are suitable for induction hobs



PV164S
Silver Glass



PV164B
White Glass



PV164N
Black Glass



SE2640TD2
Ceramic Glass

PV175S

72CM GAS HOB
SILVER GLASS



5 High-efficiency Ultraflat Vertical Flame Burners
Electric Ignition and Flame Failure Safety
Adaptable for LPG Gas or Natural gas



PV175B
White Glass



PV175N
Black Glass



SE2773CX2
Ceramic Glass

SF106

60CM ELECTRIC OVEN
SILVER GLASS



8 Function ventilated
Vapor clean function
72 Lt. Net Oven Capacity
Removable internal glass for cleaning



SF106B
White Glass



SF106N
Black Glass

A
-10%

SCA712-3

70CM ELECTRIC OVEN
SILVER GLASS



12 Function Thermo-ventilated
Back-lit knobs and 2 Halogen lights
80 Lt. Net Oven Capacity
Easy Clean Enamel
Removable internal glass for cleaning

A

60CM AND 70CM BUILT-IN SOLUTIONS - LINEA



FME120

60CM BUILT-IN MICROWAVE OVEN
SILVER GLASS



30 lt capacity
6 Cooking functions with Grill
Digital clock
Electronic controls
Cook/Defrost Auto functions
4 Power Levels
Special Duo Steam Function

VSTQ72-2

72CM UNDER MOUNTED BOWL - STAINLESS STEEL



720 x 400mm
Rectangular bowl
Under mounted
Bowl depth 210mm
Stainless steel Thickness 1mm



VSTQ40-2

FQ60XPE

92CM 4 DOOR REFRIGERATOR
STAINLESS STEEL

A+



Total Gross Capacity 610 lt
385 lt net capacity top fridge
155 lt. net capacity bottom freezers
Full No Frost / Touch Control Display
Holiday function / Economy function
Extra Fresh Zone (0° compartment)
4 controlled humidity drawers
Active Fresh Blue Light / Convertible Zone
Manual internal Icemaker

FR320P

54CM INTEGRATED
FULL FRIDGE

A+



320 lt. Gross capacity Full Refrigerator
303 lt. net capacity
1 Fan / Auto defrost
6 adjustable glass shelves
Right Hinge Reversible Door
Chrome wine rack

VI205PNF

54CM INTEGRATED
FULL FREEZER

A+



202 lt. Gross capacity Full Freezer
199 lt. net capacity
No Frost
2 shelves with flap & 5 transparent drawers
Right hinge reversible door
Fast Freeze function 4-star
Temperature acoustic alarm

DOMINO HOBS - CLASSIC AND LINEA

PGF30T

30CM TEPPANYAKI
STAINLESS STEEL



Teppanyaki
2 Independent Induction Zones
5 Power Levels
Residual Heat indicators

PGF32I-1

30CM INDUCTION HOB
STAINLESS STEEL



Induction Ceramic Black Glass
2 Induction Zones
9 Power Levels
Residual Heat indicators

PGF30F

30CM DEEP FRYER
STAINLESS STEEL



Deep Fryer with Removable Tank
3.6 lt Tank Capacity

PGF30B

30CM BARBECUE GRILLER
STAINLESS STEEL



Barbecue griller
1 Element
9 Power levels
Cast Iron Grid

PGF32C

30CM CERAMIC HOB
STAINLESS STEEL



Ceramic Black Glass
2 High-light Zones
9 Power Levels
Residual Heat indicators

PGF31G-1

30CM GAS HOB
STAINLESS STEEL



1 Gas Burner Dual Control
Triple Flame
Cast Iron Grid
Electric Ignition and
Flame Failure Safety



PGF32G



KSEG90X-1

90CM CEILING EXTRACTOR
STAINLESS STEEL



Ceiling extractor
880m³/h on intensive speed
69Db(A) Noise level on intensive speed
1 x high performance motor 340W
3 speeds plus intensives
Electronic controls + remote control included
2 x 20W halogen lights
Motor can be turned horizontally 360°
Vent outlet Ø 150mm
Optional: KITFC152 Charcoal filter for re-circulation

* Knobs kit included to match both Linea and Classic design
* LGPGF connecting strip is used to connect multiple domino hobs together

LINEA AND CLASSIC COMPACT RANGE

SC45VC2



45CM COMBI STEAMER OVEN
LINEA SILVER GLASS

Combi steam Oven
White LED Display
10 functions
38 lt. Oven Capacity
1.2 lt Water Tank
40-220°C
Stainless-Steel Interior



SC45VB2
Linea White Steamer



S45VCX2
Classic Combi Steamer

S45MX2



45CM MICROWAVE OVEN WITH
GRILL CLASSIC STAINLESS STEEL

60cm width
White LED display
Pizza Function
6 Functions
34 lt. Net Oven Capacity



SC45MB2
Linea White



SC45M2
Linea Silver Glass



SC45MCB2



45CM COMBI MICROWAVE OVEN
LINEA WHITE GLASS

60cm width
White LED display
10 Functions
Pizza function
34 lt. Net Oven Capacity



SC45MC2
Linea Silver Glass



S45MCX2
Classic

CMSC451



45CM COFFEE AND CAPPUCCINO
MACHINE - LINEA SILVER GLASS

60cm width
3 Adjustable Temp
Adjustable Grinder
Auto Rinse/Descaling
Automatic Cappuccino Function
5 Coffee Strengths / 3 Cup Sizes
1.8 lt. Tank Capacity / 15 Bar



CMSC45B
Linea White



CMS45X
Classic

CT15B-2



15CM WARMER DRAWER
LINEA WHITE GLASS

60cm width
Max Load inside drawer 25kg
Non Slip Drawer Liner
Temperature 30-75°C
Minute minder with
Auto Switch Off 0-240min



CT15-2
Linea Silver Glass



CT15X
Classic

OPERA FREESTANDING COOKERS AND EXTRACTORS

KD150X-2



150CM EXTRACTOR -
STAINLESS STEEL

2 Motors - 4 Speed, 1250m³/h Duct
67dB(A) noise level on 3rd speed, Vent 150mm

A5-8



150CM OPERA COOKER - STAINLESS STEEL

7 Burners (1UR 4.5 kW) and Electric Teflon Plate, Cast Iron Grids,
Electric Ignition and Flame Failure Safety. Left Oven: 90cm, 9 functions,
80 lt net capacity, Rotisserie, Stay clean liners. Right Oven: 60cm,
8 functions, 58 lt net capacity, pizza function, Stay clean liners



VICTORIA FREESTANDING COOKERS AND EXTRACTORS

KT110P



110CM VICTORIA EXTRACTOR - CREAM

3 Speeds, 1 High Performance Motor
760 m3/h Duct / 56 Db(A) Noise level on 3rd speed



KT110BL
Glossy Black

KT90BL



90CM VICTORIA EXTRACTOR - GLOSSY BLACK

3 Speeds, 1 High Performance Motor
760 m3/h Duct / 56 Db(A) Noise level on 3rd speed



KT90P
Cream

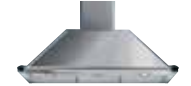

KTR90X
Stainless Steel

TR4110PF



110CM VICTORIA COOKER - CREAM

7 burners, Cast iron grids, Electric ignition, Teppanyaki Plate, 3 Ovens and one storage drawer, Main ovens: 63 litres net capacity, Vapor clean function, Roof liner, Removable inner glass. Auxiliary grill oven: 36 lt net capacity, Roof liner, Full glass inner door



TR4110BLF
Glossy Black

TR90BL



90CM VICTORIA COOKER - GLOSSY BLACK

5 burners, Cast iron grids, Electric ignition, 119 litres net oven capacity, Double Thermo-Ventilated, Electric Grill, Metal Side racks, Ever clean enamel, Digital Clock, Rotisserie, Full glass inner door, Storage Compartment



TR90P
Cream



TR90X
Stainless Steel



TR4110RWF
Burgundy



TR4110SF
Silver



TR4110AZ
Pastel Blue



TR4110RO
Pastel Pink

NEW SMALL DOMESTIC APPLIANCES RANGE

TSF01 2 Slice Toaster



TSF02 4 Slice Toaster



KLF01 Kettle



KLF02 Variable Temperature Kettle



BLF01 Blender



SMF01 Stand Mixer



* Arriving end of year 2014



SYMPHONY AND CONCERT FREESTANDING COOKERS AND EXTRACTORS

KV90X-1



90CM WALL EXTRACTOR
STAINLESS STEEL

3 Speed / 2 Halogen Lights / 660m³/h Ducted
63 Db(A) Noise level on 3rd speed

KSED95P9



90CM EXTRACTOR
CREAM

3 Speed / 700m³/h Ducted
72 Db(A) Noise level



KSED95X-1
Stainless Steel

C9GMRSSA



90CM GAS/ELECTRIC COOKER
RED

6 Burners / 8 Functions
119 lt. Net Capacity
Double Thermo-Ventilated
Rotisserie / Electric grill
Storage Compartment
Metal side racks



C9GMPSSA
Cream



C9GMBSSA
White



C9GMXSSA
Stainless Steel

SSA91MFP9



90CM GAS/ELECTRIC
COOKER CREAM

5 Burners / Electric Ignition
Flame Failure safety device
115 lt. Net Oven Capacity
6 Functions electric oven
Easy Clean Enamel
Storage Compartment
Double Fan / Rotisserie



SSA91MFA1
Anthracite



SSA91MRW1
Burgundy



SSA91MFX1
Stainless Steel



SYMPHONY AND CONCERT FREESTANDING COOKERS AND EXTRACTORS

C9GGSSA-1



90CM FULL GAS COOKER
STAINLESS STEEL

- 6 Burner
- Cast Iron Grids
- Flame Failure Safety
- 119 lt. Net Oven Capacity
- Double Fan assisted Gas Oven
- Gas Grill
- Storage Compartment

C6GVX18



60CM FULL GAS COOKER
STAINLESS STEEL

- 4 Burner Gas
- Flame Failure Safety
- Single Fan assisted Gas Oven
- Electric Grill
- 72 lt. Net Oven Capacity
- Metal side racks with telescopic guides

SSA91GGX1



90CM FULL GAS COOKER
STAINLESS STEEL

- 5 Burner Gas
- Flame Failure Safety device
- Electric Ignition
- Cast Iron Grids
- Gas Oven
- Gas grill
- 115 lt. Net Oven Capacity
- Rotisserie
- Storage Compartment

SSA60GGX9



60CM FULL GAS COOKER
STAINLESS STEEL

- 4 Burner Gas
- Flame Failure Safety device
- Electric Ignition
- Cast iron grids
- Gas Oven
- Gas grill
- 72 lt. Net Oven Capacity
- Storage Compartment

SSA92MFX9



90CM GAS/ELECTRIC COOKER
STAINLESS STEEL

- 4 Burner Gas
- 2 Electric Solid Plates
(3 Gas Norm/1 URP 3.2kW)
- Flame Failure Safety
- Electric Ignition
- Cast Iron Grids
- Electric Oven
- Double Thermo-Ventilated

SSA60MX9



60CM GAS/ELECTRIC COOKER
STAINLESS STEEL

- 4 Burners
- 3 Norm/1 UR 3.5kW
- Cast Iron Grids
- Electric Ignition
- Flame Failure Safety
- Thermo-Ventilated
- 7 Functions
- 72 lt. Net Oven Capacity
- Storage Compartment
- Vapor Clean function

SCD91CMX5



90CM FULL ELECTRIC COOKER
STAINLESS STEEL

- 5 Plate Ceran Hob
- Auto Safety Cut-Out
- Electric Oven 6 Functions
- Double Thermo-Ventilated
- Storage Compartment
- 115 lt. Net Oven Capacity
- Rotisserie

CX68CM8



60CM FULL ELECTRIC COOKER
STAINLESS STEEL

- 4 Ceran Plates
- 8 Functions
- Thermo-Ventilated
- Digital Electronic
- Variable grill
- 72 lt. Net Oven Capacity
- Vapor Clean function

DISHWASHERS



FlexiDuo third cutlery basket

DF13SS



60CM FREESTANDING DISHWASHER - STAINLESS STEEL

- 13 Place Setting
- Flexi Duo top cutlery basket
- 5+5 Quick Programmes
- Quick time option
- 1/2 Load Flexizone Option
- Orbital Plus Washing System
- 39dB Noise Level
- Water consumption: 9 lt./cycle
- Total Aquastop
- End of cycle automatic door opening

LVS375SX



60CM FREESTANDING DISHWASHER - STAINLESS STEEL

- 13 Place Setting
- Flexi Duo top cutlery basket
- 7+6 Quick Programmes
- Quick time option
- 1/2 Load Flexizone Option
- Hyclean sanitising Option
- Orbital plus washing system
- 45dB Noise Level
- Water consumption: 9 lt./cycle
- Total Aquastop
- End of cycle automatic door opening

DC134LW



60CM FREESTANDING DISHWASHER - WHITE

- 13 Place Setting
- Flexi duo top cutlery basket
- 7+6 Quick Programmes
- Quick time option
- Water consumption: 9.8 lt./cycle
- 1/2 Load Flexizone Option
- Orbital plus washing system
- 43dB (A) Noise Level
- Total Aquastop

LSA6445X2



60CM FREESTANDING DISHWASHER - STAINLESS STEEL

- 13 Place Setting
- 7 Programmes
- Speed 27 min
- Sanitizing option Hyclean
- 1/2 Load Flexizone Option
- Orbital plus washing system
- Water consumption: 9.5 lt./cycle
- 45dB (A) Noise Level

LVS65SSA



60CM FREESTANDING DISHWASHER - SILVER

- 12 Place Setting
- 5 Programmes / Speed 27 Min
- Upper Basket adjustable on 2 Levels
- Water consumption: 12 lt./cycle
- 1/2 Load Flexizone Option
- Hyclean Sanitizing Option
- Orbital Plus System
- 49dB Noise Level



LVS65WSA
White



Half load Flexi Zone:

The 1/2 load FlexiZone allows you to wash a reduced load saving energy, water and time and there are no restrictions on where the items are placed. Traditional half loads allow only one of the baskets to be used. Flexi-Zone can be found on most dishwashers, as either an option or a programme depending on the model.

Anti Drip System:

An exclusive anti-drip system is fitted to the front of the basket to prevent irritating drips on the floor as the basket is extracted. It is designed to improve the drying performance of the dishwasher.



WDF147XS



60CM FREESTANDING WASHER DRYER - STAINLESS STEEL

- 15 Washing Programmes
- 6 Drying Programmes
- 1400rpm Variable Spin
- 7kg Washing Capacity
- 4kg Drying Capacity
- 5 Temp
- Auto Variable Load
- Wide Door 30cm Diameter

WMF147X



60CM FREESTANDING WASHING MACHINE - STAINLESS STEEL

- 7 kg Front Load
- 1400rpm Variable Spin Speed
- 15 Programmes
- 5 Temp
- Water consumption: 47 lt./cycle
- Auto Variable Load
- Child Lock
- Wide Door 30cm Diameter

WM148WSA



60CM WASHING MACHINE - WHITE

- 8kg Front Load
- 1400rpm Variable Spin
- 15 Wash Programmes
- Auto Variable Load
- Water consumption: 65 lt./cycle
- Total Aqua Stop

DRY8WSA



60CM CONDENSER DRYER - WHITE

- 8kg Front Load Condenser Dryer
- 11 Programmes
- Humidity sensor
- Stainless Steel Drum
- Easy Clean Filter
- 112 Litre Drum Capacity
- Child Safety Lock

WM128SSA



60CM WASHING MACHINE - SILVER

- 8kg Front Load
- 1200rpm Variable Spin
- 15 Wash Programmes
- Auto Variable Load
- Water consumption: 65 lt./cycle
- Total Aqua Stop

DRY8SSA



60CM CONDENSER DRYER - SILVER

- 8kg Front Load Condenser Dryer
- 11 Programmes
- Humidity sensor
- Stainless Steel Drum
- Easy Clean Filter
- 112 Litre Drum Capacity
- Child Safety Lock



FREESTANDING REFRIGERATION

SBS63XED

A+

90CM SIDE BY SIDE REFRIGERATORS
NO FROST - STAINLESS STEEL



Gross capacity 552 lt
Touch LCD display
Ice and water dispenser
Extra-fresh zone • Refrigerator with
2 drawers with Freezer internal lighting
Fast freezing compartment
Dimensions (Height/Width/Depth): 1820/910/782 mm

FC336XPNF

A+

60CM FRIDGE FREEZER COMBINATION
NO FROST - STAINLESS STEEL



Gross Capacity 335 lt
231lt Fridge net capacity
87lt Freezer net capacity
Frost Free
Reversible Doors
Energy Rating A+
Reversible Doors
Dimensions (Height/Width/Depth):
1850/600/650 mm (handle included)

CV26PXNF3

A+

60CM SINGLE DOOR FREEZER
STAINLESS STEEL



Gross Capacity 265 lt
251 lt. Freezer net capacity
Frost Free
Adjustable Thermostat / Fast-Freeze Function
Reversible Door
Energy Rating A+
Side by side with FA35PX3
Dimensions (H/W/D): 1850x595x635mm
With 90° opened door: 660 mm (handle included)

FA35PX3

A+

60CM SINGLE DOOR FRIDGE
STAINLESS STEEL



Gross Capacity 353 lt
349 lt. Freezer net capacity
Anti-Bacterial Protection
1 Adjustable Thermostat / Auto Defrost
Reversible Doors
Energy Rating A+
Side by side with CV26PXNF3
Dimensions (H/W/D): 1850x595x635 mm
With 90° opened door: 660 mm (handle included)



FAB50P
Cream

FAB32RRN1
Red

FAB30RAZ1
Pastel blue

FAB28RVE1
Lime green

CVB20RO
Orange

FAB10RUJ
Union Jack

FAB50



FAB50P
Cream

FAB50B
White

FAB50X
Silver

FAB32



FAB32RRN1
Red

FAB32RPN1
Cream

FAB32RNE1
Black

FAB32RBN1
White

FAB32RXN1
Silver

FAB32RAZN1
Pastel blue

FAB32RVN1
Lime green

FAB32RVN1
Pastel green

FAB32RON1
Orange

FAB32RRON1
Pastel pink

FAB32RBLN1
Blue

FAB30



FAB30RR1
Red

FAB30RP1
Cream

FAB30RNE1
Black

FAB30RB1
White

FAB30RX1
Silver

FAB30RAZ1
Pastel blue

FAB30RVE1
Lime green

FAB30RV1
Pastel

FAB30RO1
Orange

FAB30RRO1
Pastel pink

FAB30RBL1
Blue

FAB28



FAB28RR1
Red

FAB28RP1
Cream

FAB28RNE1
Black

FAB28RX1
Silver

FAB28RAZ1
Pastel blue

FAB28RVE1
Lime green

FAB28RV1
Pastel green

FAB28RO1
Orange

FAB28RRO1
Pastel pink

FAB28RBL1
Blue

FAB28RG1
Yellow

FAB28RB1
White

CVB20



CVB20RR
Red

CVB20RP
Cream

CVB20RNE
Black

CVB20RO
Orange

FAB10



FAB10RR
Red

FAB10RP
Cream

FAB10RNE
Black

FAB10RO
Orange

FAB10RUJ
Union Jack

DOMESTIC PRO-LINE



LP364X



DOMESTIC PRO-LINE DISHWASHER
STAINLESS STEEL - ANTIFINGERPRINT

- 14 place settings
- FlexiDuo third cutlery basket
- 5 domestic programs
- 4 professional programs
- Ultra Quick 16 Minute Wash
- Flexi-Zone ½ load option
- Adjustable upper basket on 3 levels
- Orbital plus washing system
- Smart load sensor
- Total Aquastop
- 45 db(A)
- Single or Three phase Connection

FAB5RNE

SUPER SILENT PROFESSIONAL ABSORPTION MINIBAR



FAB5RR
Red



FAB5RP
Cream



FAB5RO
Orange

- 50's style aesthetic
- Absorption refrigeration system
- Adjustable thermostat
- Automatic defrost
- Right hand opening hinges
- LED internal light
- Shelves with adjustable height
- No.1 door bottle balcony with adjustable height and depth
- No.1 door snack balcony
- Ice cubes container

SCV115-1

60CM FREE-STANDING OR BUILT-IN WINE COOLER
GLASS DOOR



- 115 Bottles
- 368 lt. Capacity
- Two internal temperature zones
- Anti UV ray door
- Electronic control panel
- Temperature range from 5°C to 22°C
- Internal LED light
- Automatic defrost
- Anti vibration compressors
- Active carbon filter
- 6 Wooden shelves
- Right or Left Hand Hinge



BIBQ1205H

BUILT-IN OUTDOOR BARBECUE - STAINLESS STEEL



- 117cm Wide
- AISI 316 Marine grade satin Stainless steel
- 5 Stainless steel burners
- Double insulated hood, with 0–400°C thermostat
- Stainless steel interlocking grill system
- Stainless steel hotplate and warming rack
- Adaptable for LPG or Natural Gas

SINKS AND BOWLS

VQ72F-2

72CM FLUSH-FITTED BOWL - STAINLESS STEEL



720 x 400mm Rectangular Bowl
Flush-Fitted
Total size 786x464mm
Bowl depth 210mm
Stainless steel Thickness 1mm



VQ40F-2
400mm

VSTQ72-2

72CM UNDER MOUNTED BOWL - STAINLESS STEEL



720 x 400mm Rectangular bowl
Under mounted
Bowl depth 210mm
Stainless steel Thickness 1mm



VSTQ40-2
400mm

LG116D

116CM DOUBLE BOWL INSET SINK - STAINLESS STEEL



1160x500mm
1.5 Bowl and Drainer 450 x 400mm/300 x 400mm
Right (D) or Left (S) Hand Drainer
Ultra Low profile - Bowl Depth 210mm
Stainless steel Thickness 0.7mm

LL116D

116CM DOUBLE BOWL INSET SINK - STAINLESS STEEL



1160 x 500mm
Double Bowl 350 x 400mm
Right (D) or Left (S) Hand Drainer
Ultra Low profile - Bowl Depth 210mm
Stainless steel Thickness 0.7mm

UM45

45CM UNDER MOUNTED BOWL
STAINLESS STEEL



450 x 400mm single bowl
Bowl Depth 180mm
Stainless steel Thickness 0.7mm

UM30

30CM UNDER MOUNTED BOWL
STAINLESS STEEL



300 x 400mm single bowl
Bowl Depth 180mm
Stainless steel Thickness 0.7mm

BST103P

43CM UNDER MOUNTED BOWL
STAINLESS STEEL



430mm Round single bowl
Bowl Diameter 375mm
Bowl Depth 200mm
Stainless steel Thickness 1mm

SP3A

83CM CORNER INSET SINK - STAINLESS STEEL



830 x 830mm
Corner Inset Sink 2.5 Bowls
2 Bowls 340 x 400mm & 1 Half bowl
165mm x 300mm - Bowl Depth 210mm
Stainless steel Thickness 0.7mm

VS34/P3

50CM INSET SINK - STAINLESS STEEL



1 bowl inset sink
1 bowl 340mm
Drain: 3.5"
Bowl depth: 210mm

10I3P

43CM INSET BOWL - STAINLESS STEEL



Round bowl inset sink
Bowl diameter 430mm
Bowl depth 200mm
Stainless steel Thickness 1mm

TECHNICAL DRAWINGS

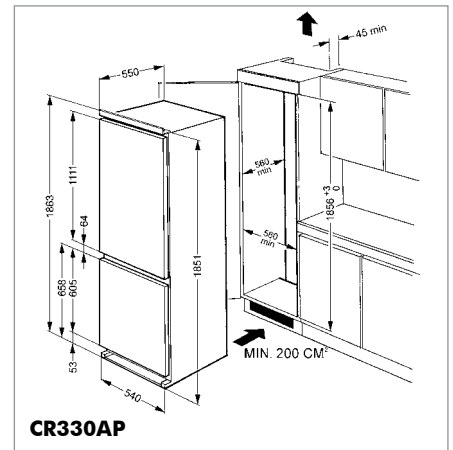
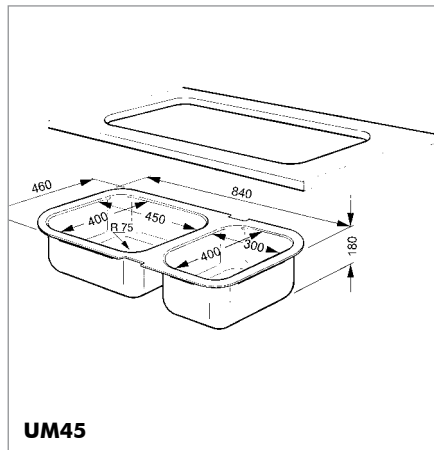
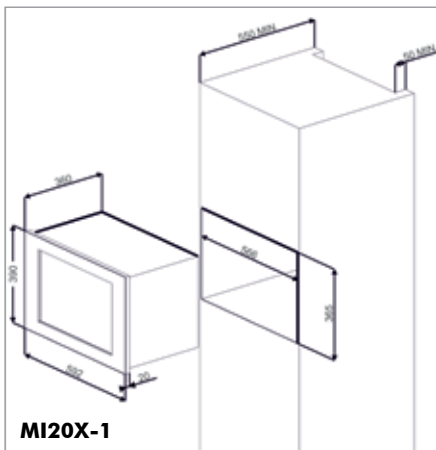
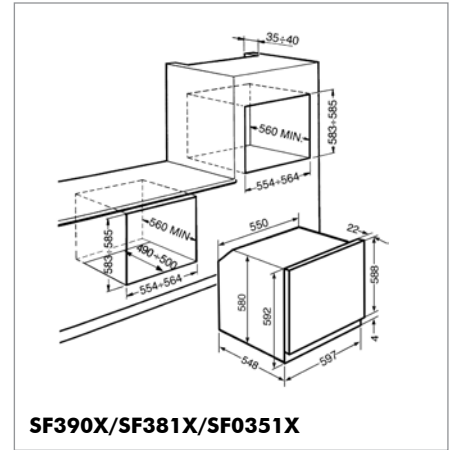
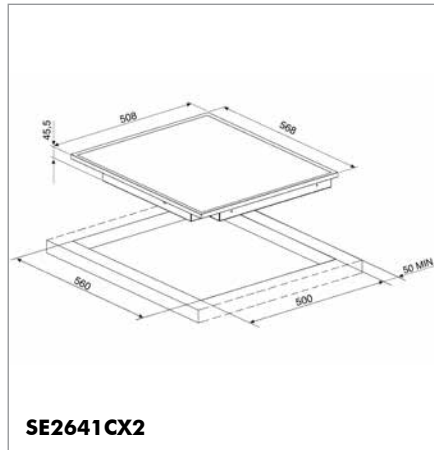
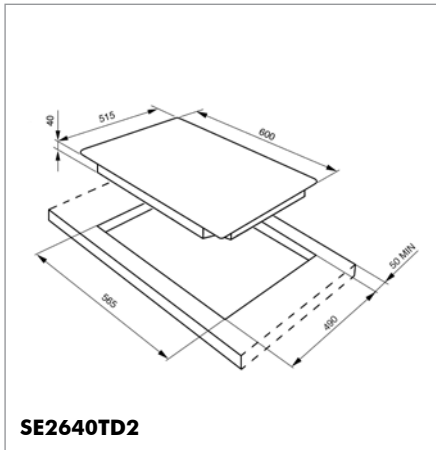
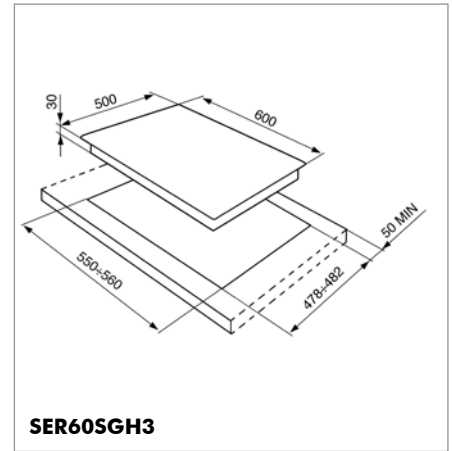
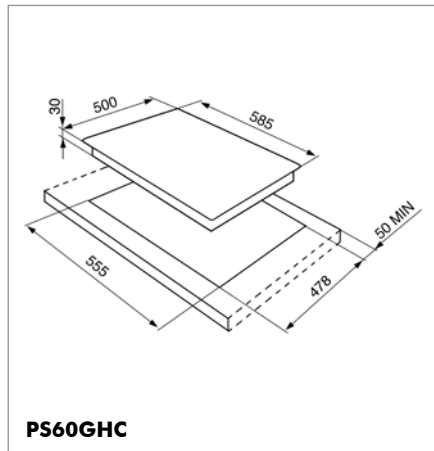
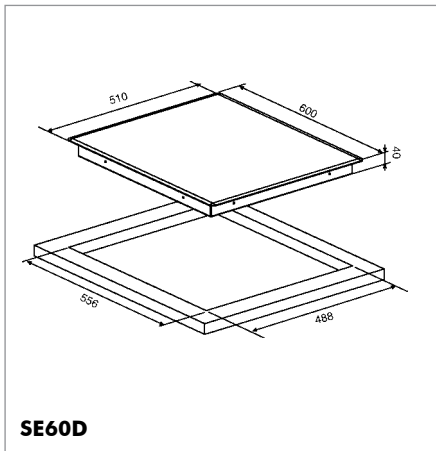
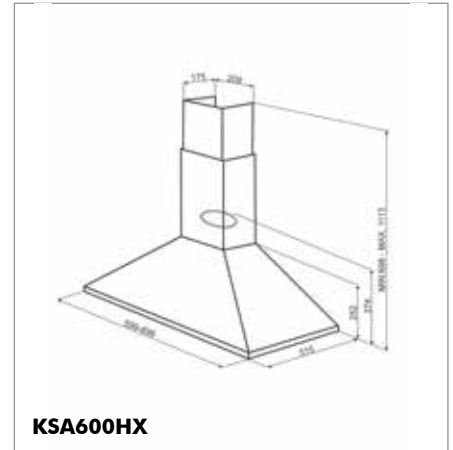
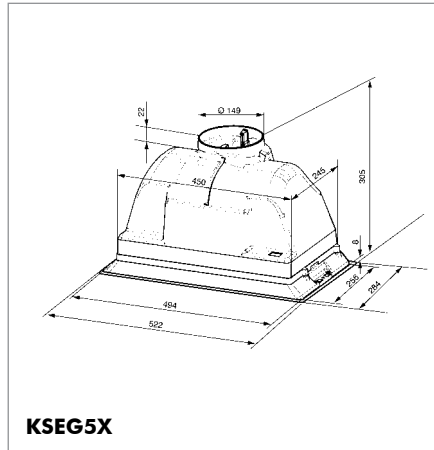
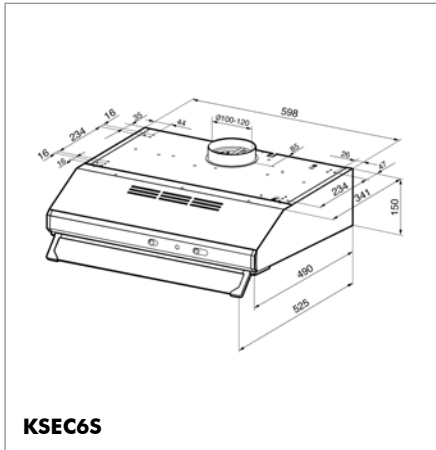

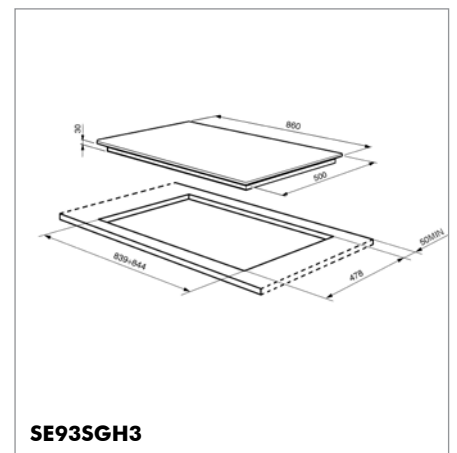
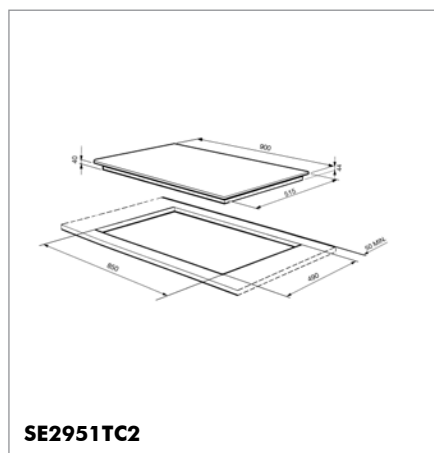
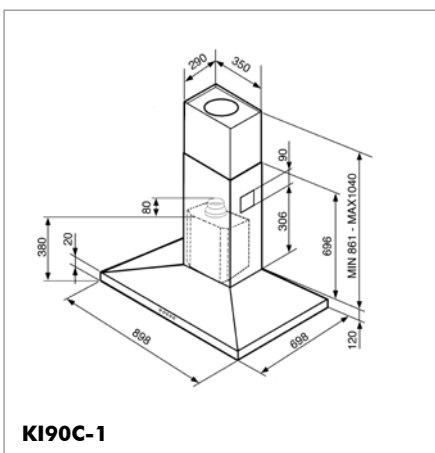
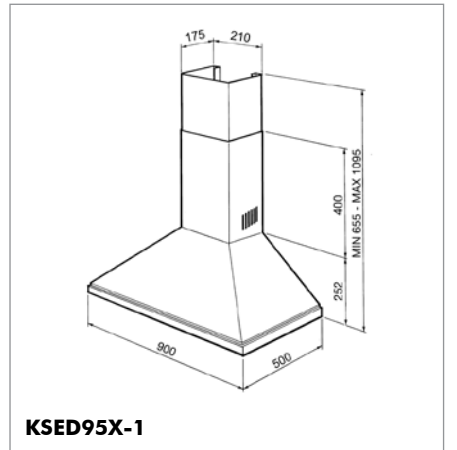
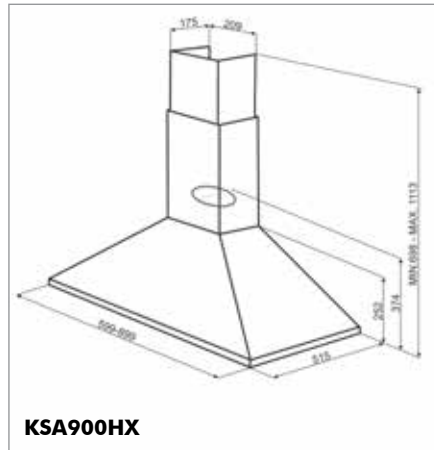
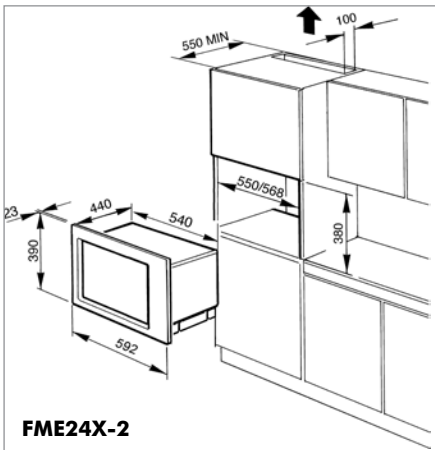
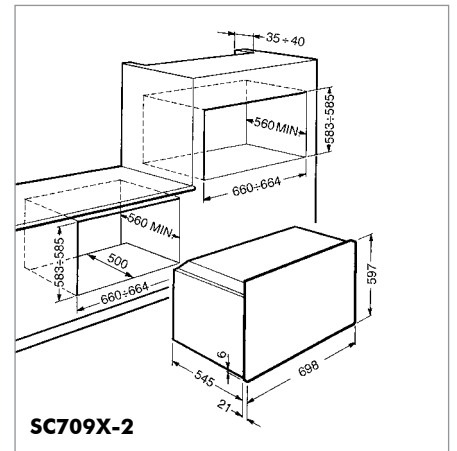
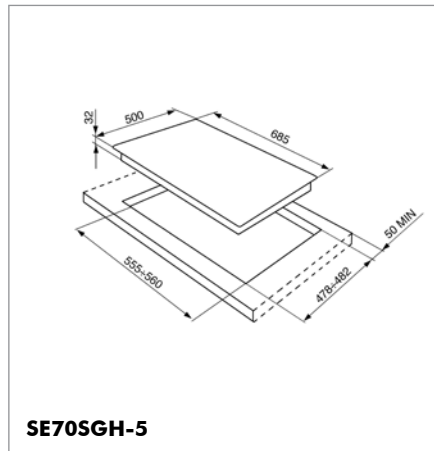
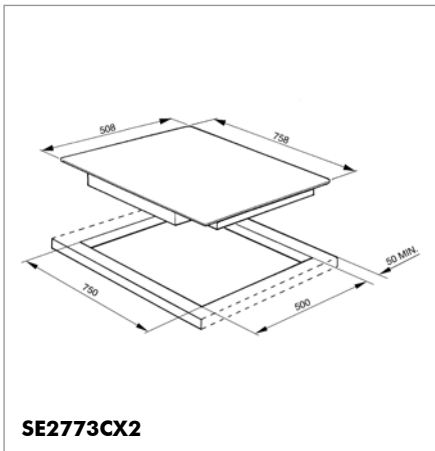
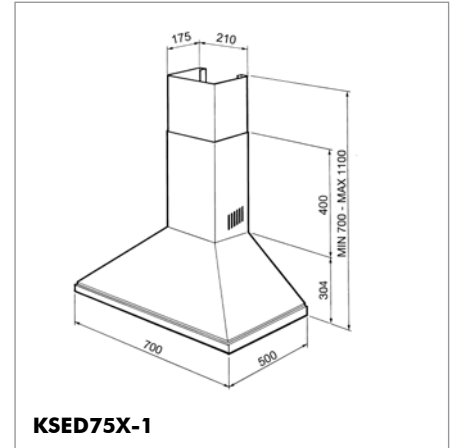
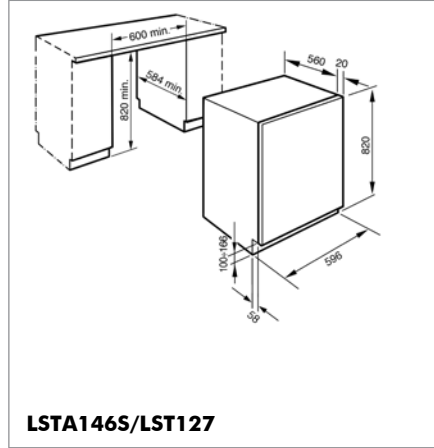
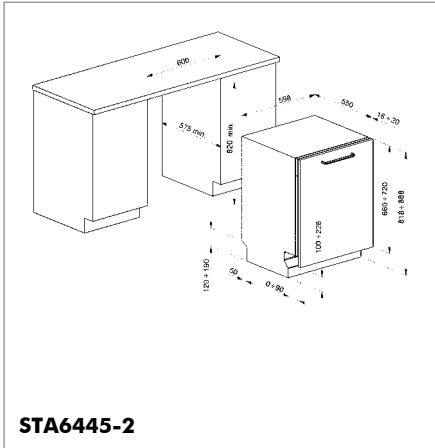

TECHNICAL DRAWINGS

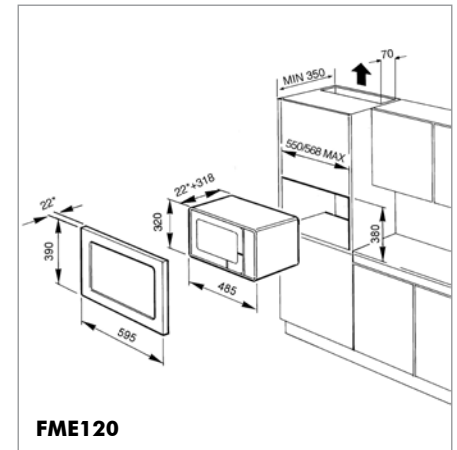
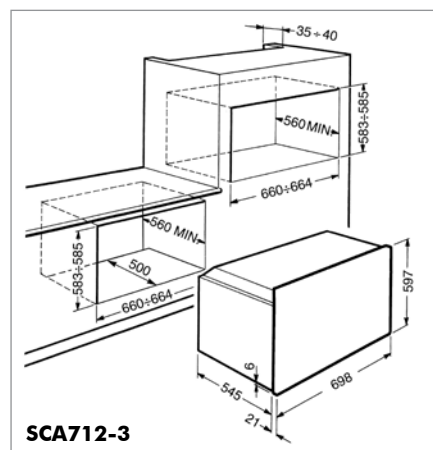
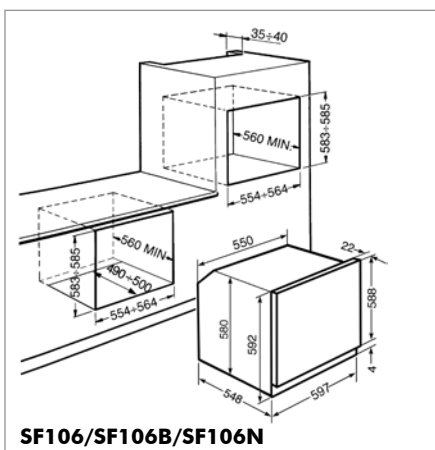
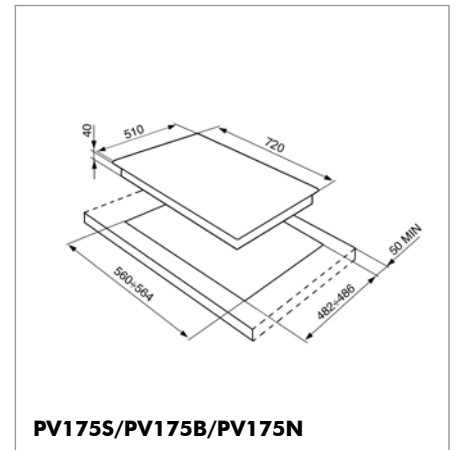
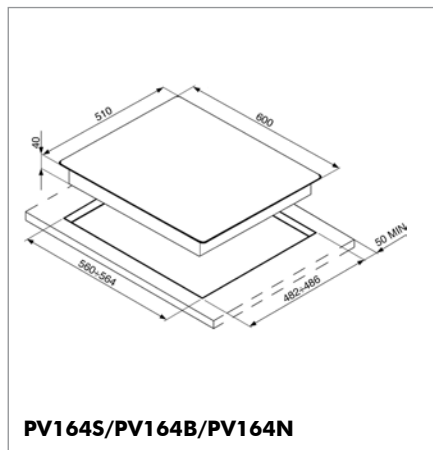
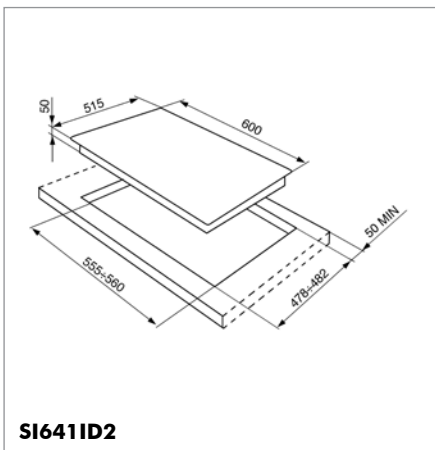
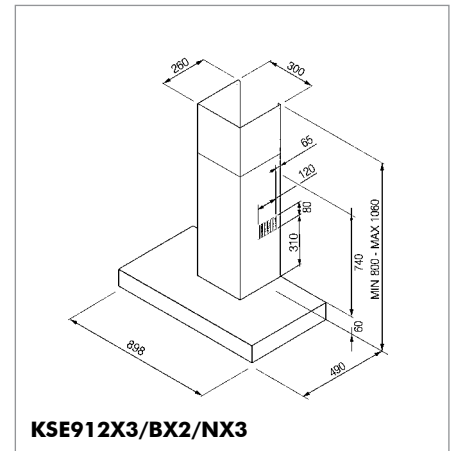
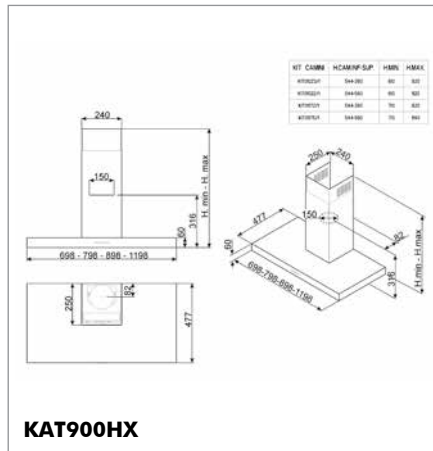
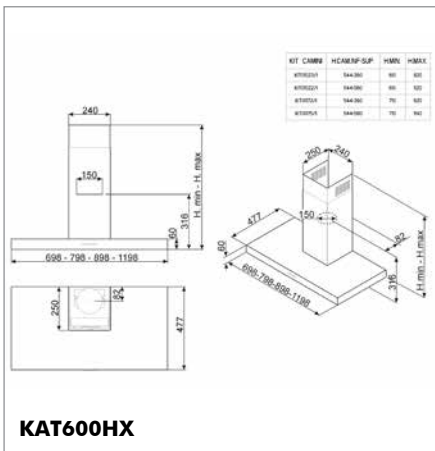
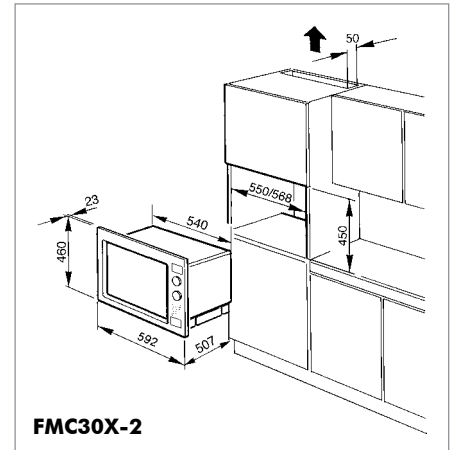
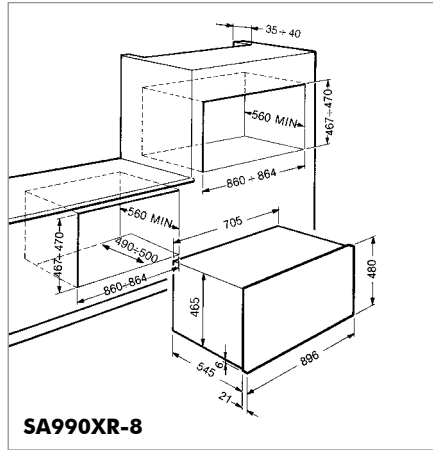
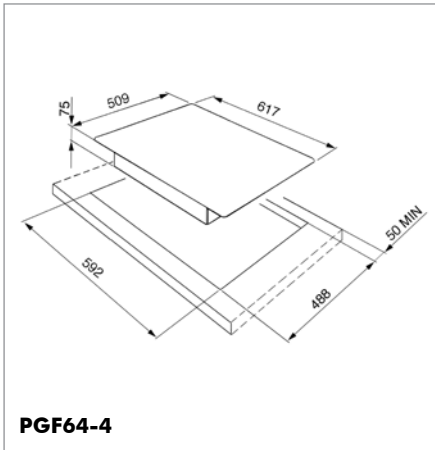

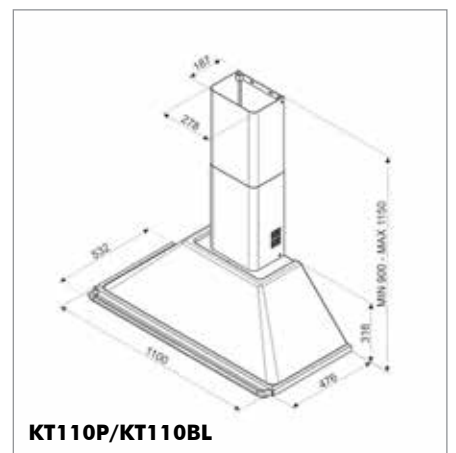
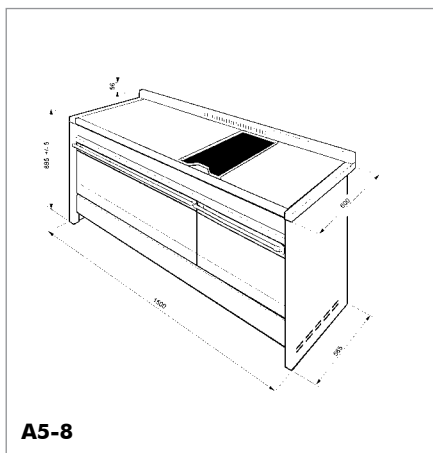
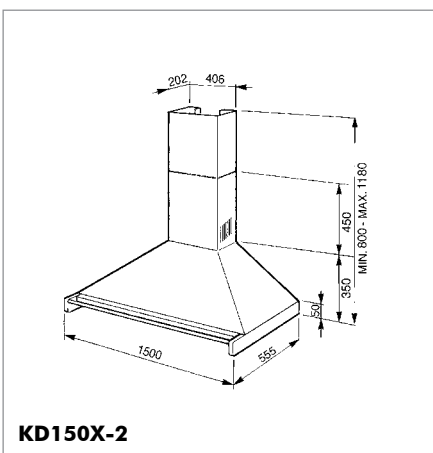
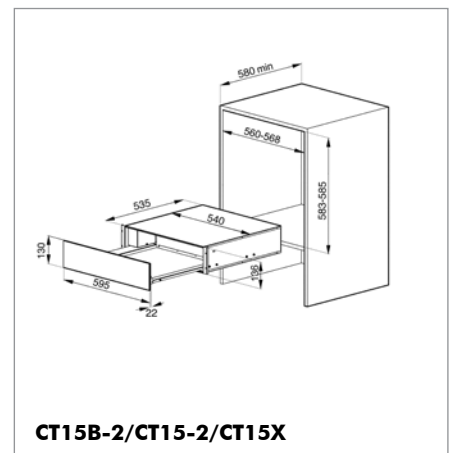
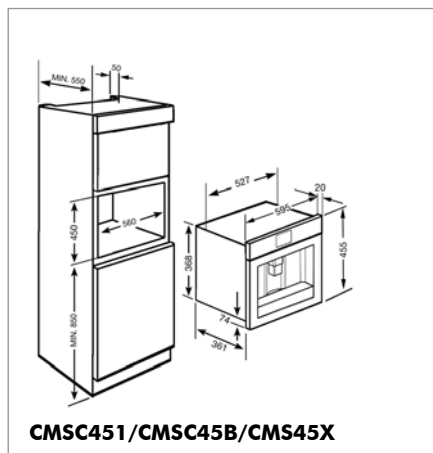
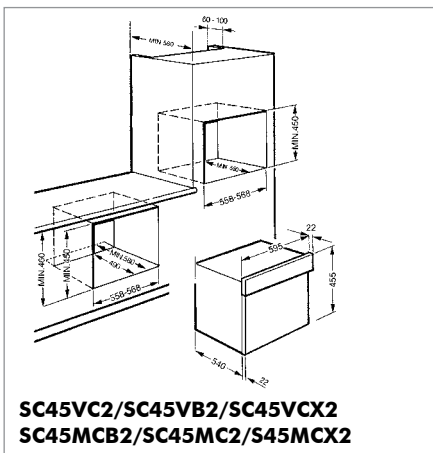
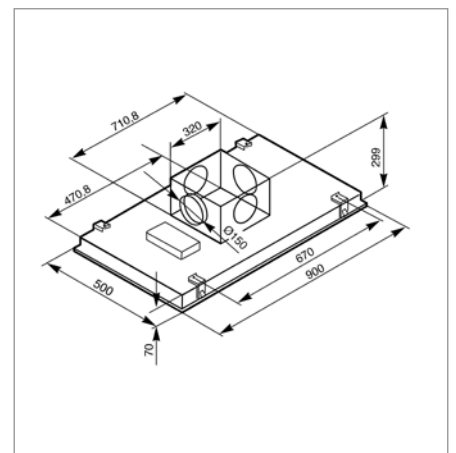
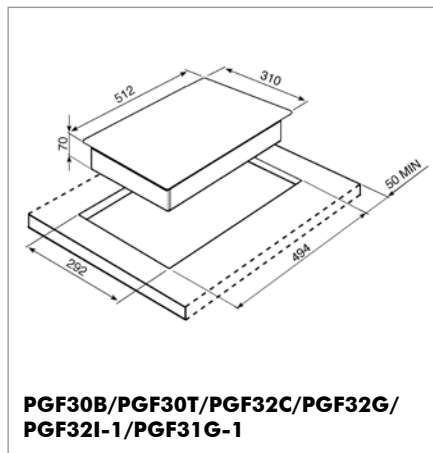
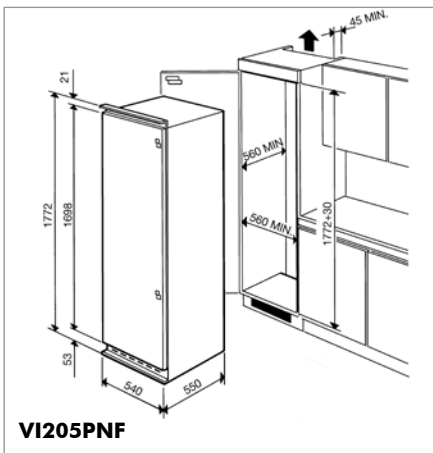
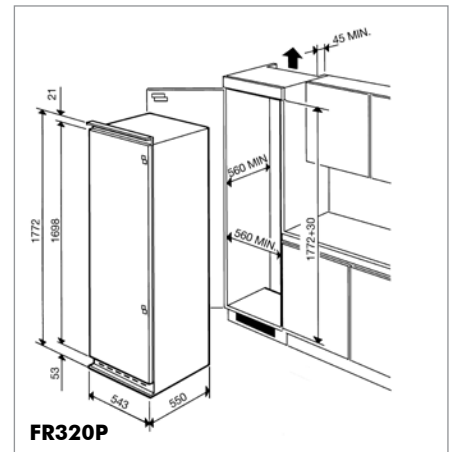
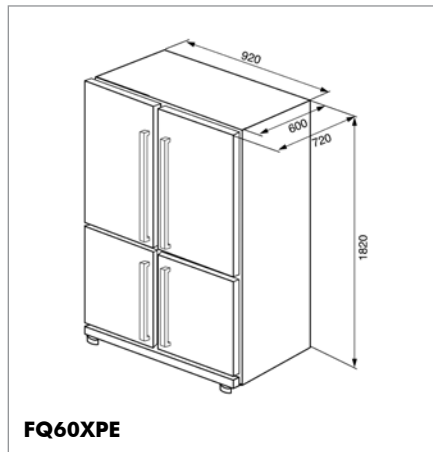
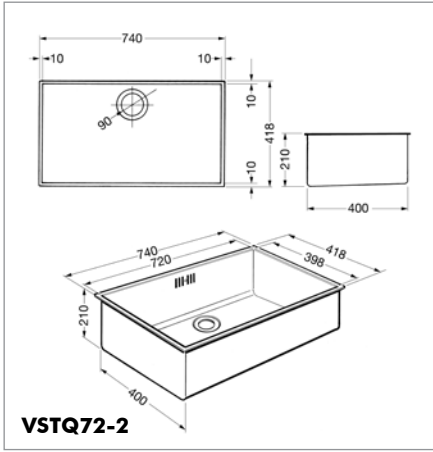

TECHNICAL DRAWINGS

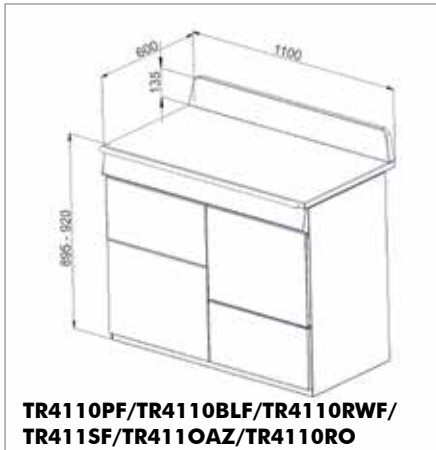

**TR4110PF/TR4110BLF/TR4110RWF/
TR4115F/TR4110AZ/TR4110RO**

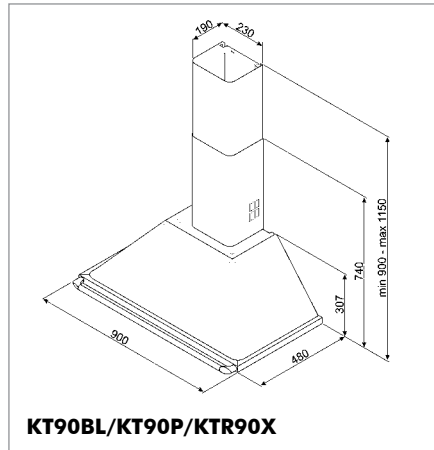

KT90BL/KT90P/KTR90X

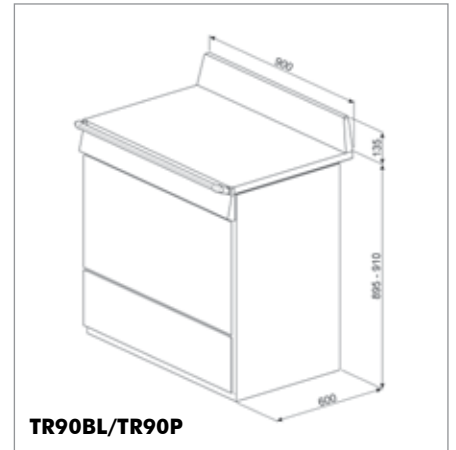

TR90BL/TR90P

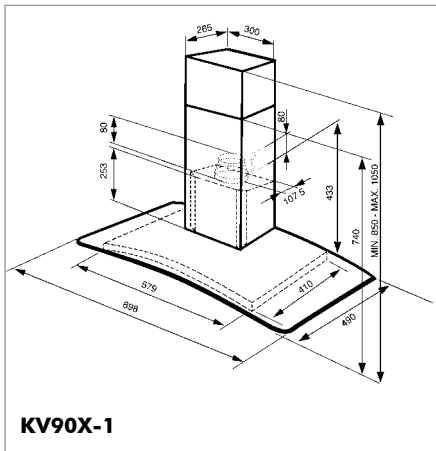

KV90X-1

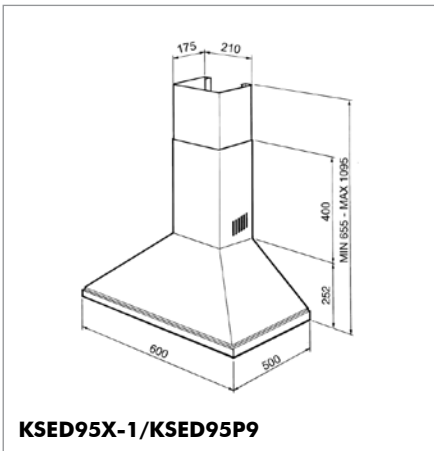

KSED95X-1/KSED95P9

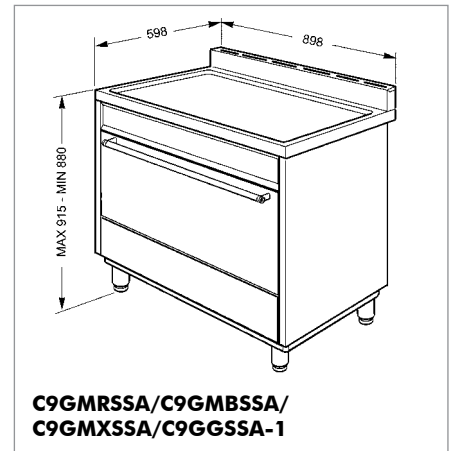

**C9GMRSSA/C9GMBSSA/
C9GMXSSA/C9GGSSA-1**

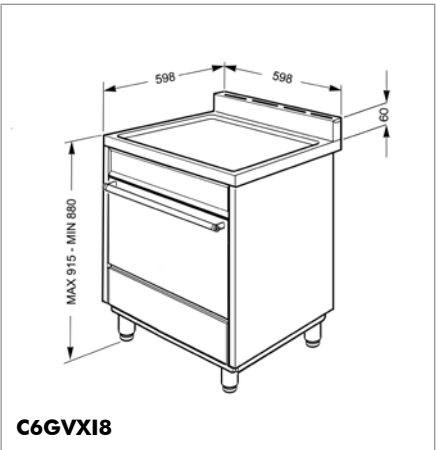

C6GVX18

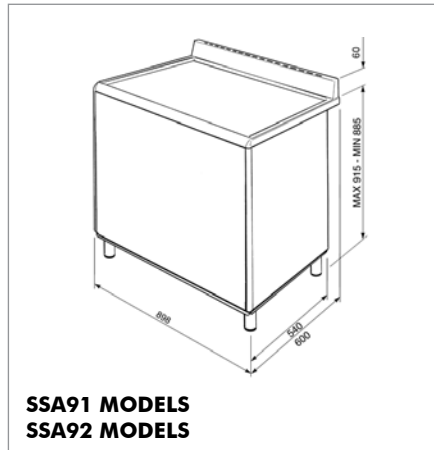

**SSA91 MODELS
SSA92 MODELS**

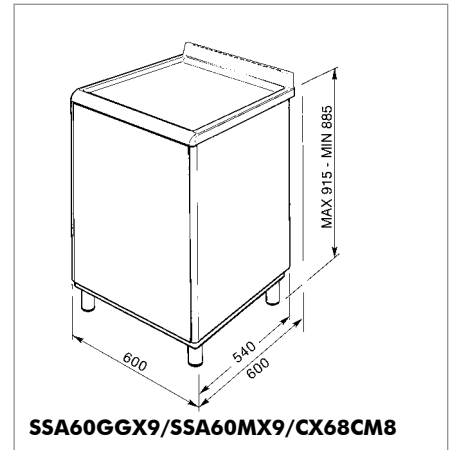

SSA60GGX9/SSA60MX9/CX68CM8

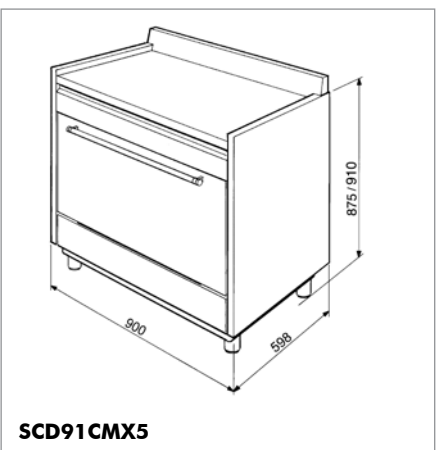

SCD91CMX5

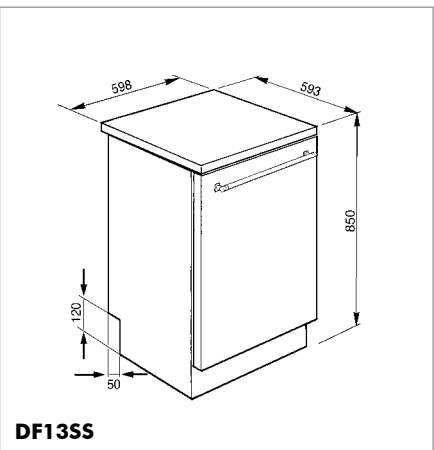

DF13SS

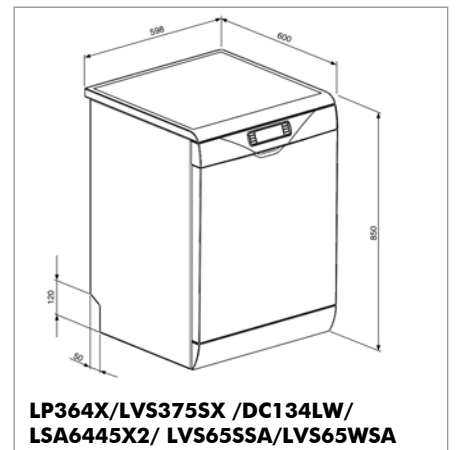

**LP364X/LVS375SX /DC134LW/
LSA6445X2/ LVS65SSA/LVS65WSA**

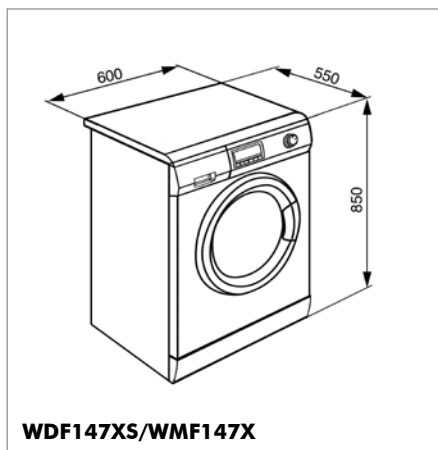

WDF147XS/WMF147X



WM148WSA/ WM128SSA

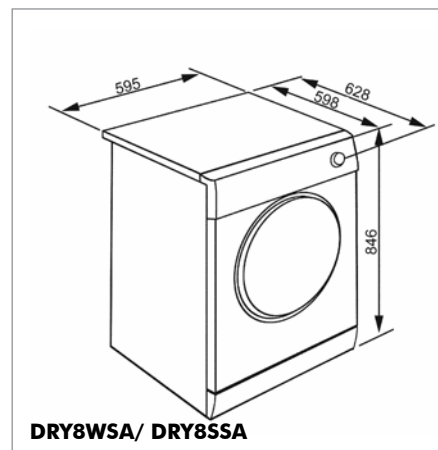

DRY8WSA/ DRY8SSA

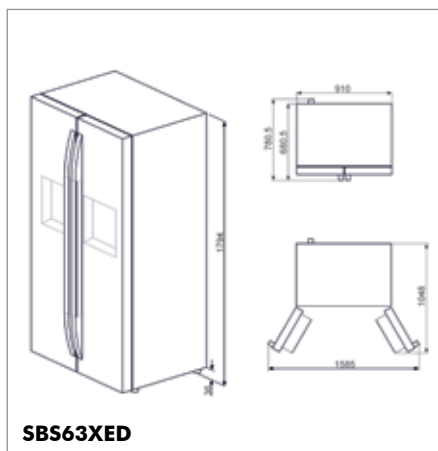

SBS63XED



FC336XPNF



CV26PXNF3/FA35PX3



FAB50



FAB32



FAB30

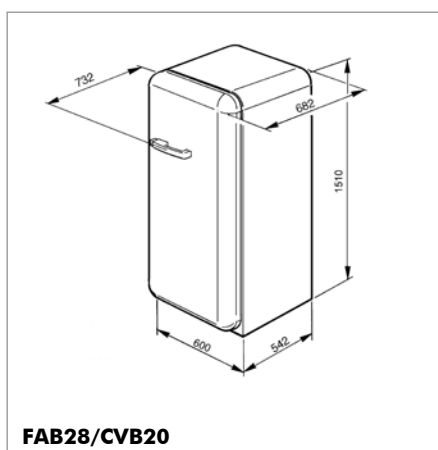

FAB28/CVB20

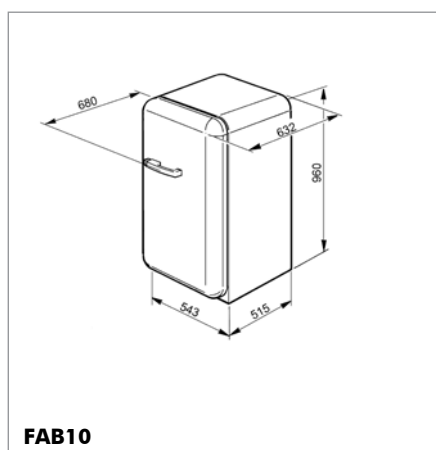

FAB10

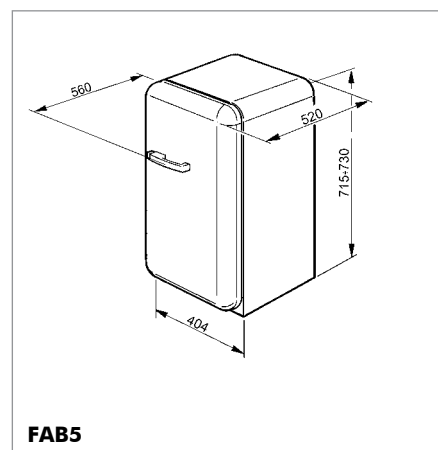

FAB5

TECHNICAL DRAWINGS

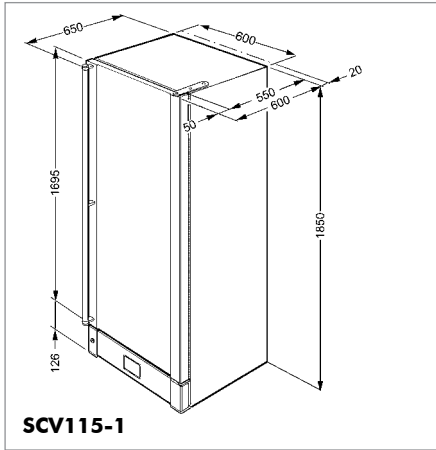

SCV115-1

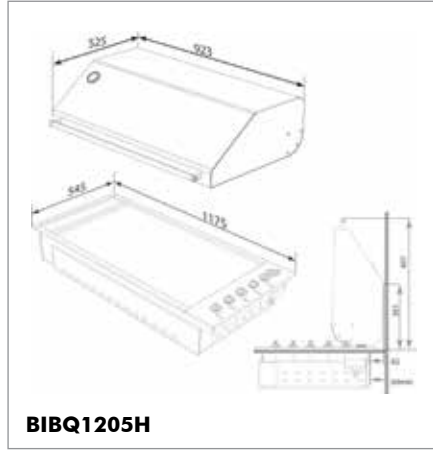

BIBQ1205H

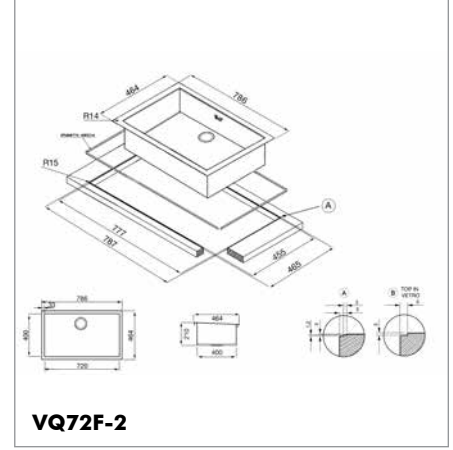

VQ72F-2

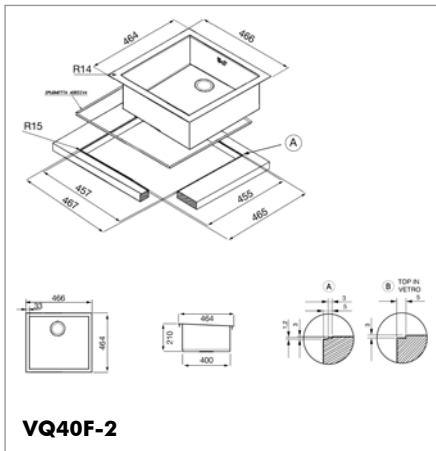

VQ40F-2

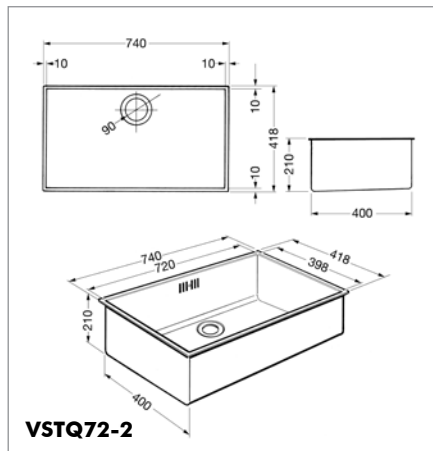

VSTQ72-2

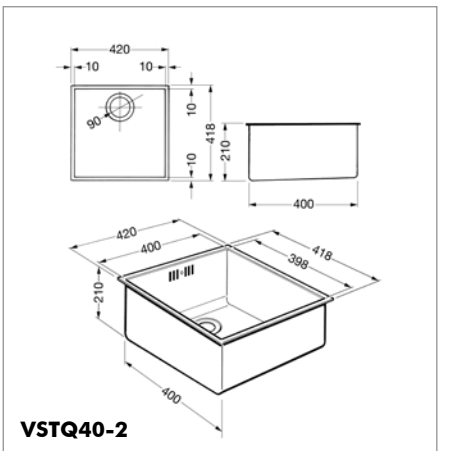

VSTQ40-2

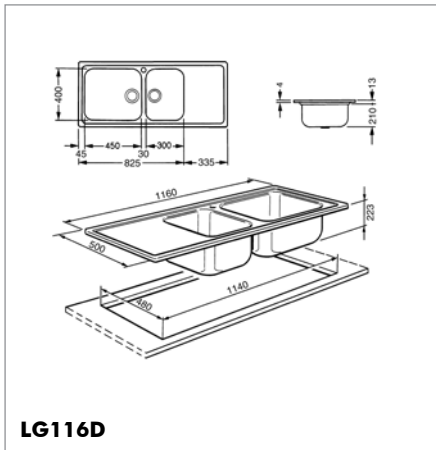

LG116D

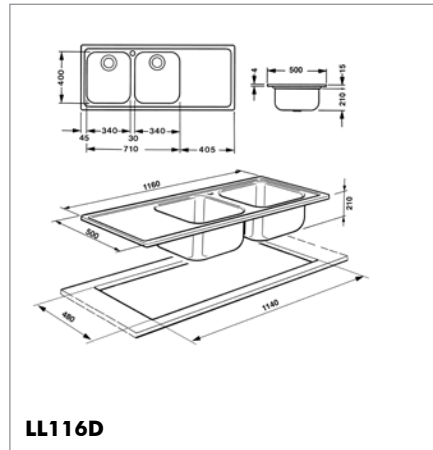

LL116D

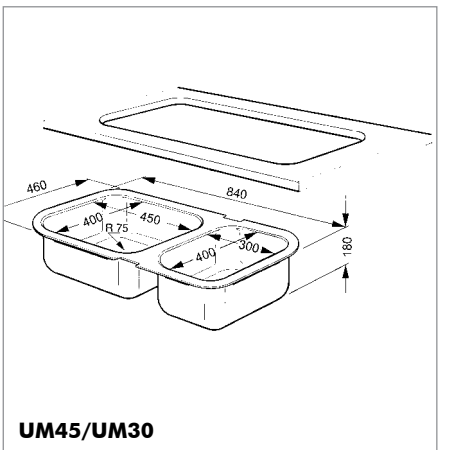

UM45/UM30

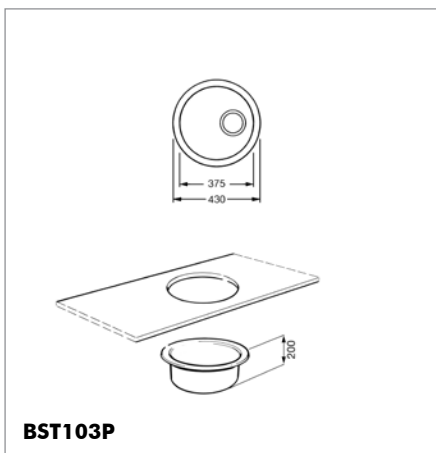

BST103P

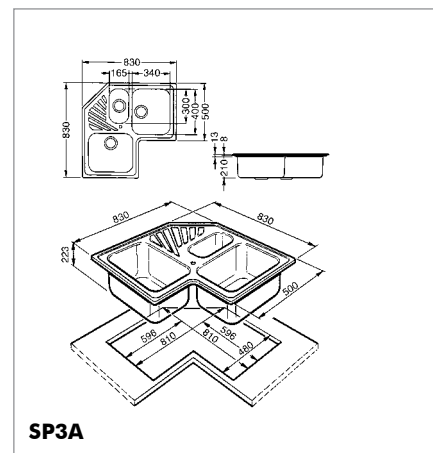

SP3A



VS34-P3/10I3P

JOHANNESBURG SHOWROOM



CAPE TOWN SHOWROOM



UMHLANGA SHOWROOM



JOHANNESBURG

2985 William Nicol Drive,
Cnr Bryanston Drive,
Bryanston
Tel: (011) 463 1016

Hours:

Mondays - Fridays 08:30 to 17:00
Saturdays 09:00 to 14:00

CAPE TOWN

120 Strand Street,
Cnr Buitengracht Street,
De Waterkant
Tel: (021) 418 9934

Hours:

Monday - Fridays 08:00 to 16:30
Saturdays 09:00 to 14:00

UMHLANGA

31A, Solstice Road,
Newtown Centre,
Umhlanga Ridge
Tel: (031) 566 2770

Hours:

Monday - Fridays 08:00 to 16:30
Saturdays 09:00 to 14:00





SMEG South Africa

Johannesburg Head office and Showroom:

2985 William Nicol Drive (Cnr Bryanston drive), Bryanston
tel: (011) 463 1016

Cape Town Showroom:

120 Strand Street, Cnr Buitengracht Street, De Waterkant
tel: (021) 418 9934

Umhlanga Showroom:

31A, Solstice Road, Newtown Centre, Umhlanga Ridge
tel: (031) 566 2770

Service Department:

89 Impala Road, Kelvin view, Eastgate Ext.8 (off Marlboro)
tel: (011) 656 0025

National Call Center: 0860 102 984

e-mail: info@smegsa.co.za

Web site: www.smeg.co.za