

GRS Brownbuilt

Global Roofing Solutions Brownbuilt™

ROOFING LIKE NO OTHER

Talk to **THE SMART ROOF PEOPLE**
www.globalroofs.co.za
marketing@globalroofs.co.za



GRS Brownbuilt



BrownBuilt | HH Robertson



Typical Specification

Materials

The roofing / side cladding shall be Brownbuilt profile, roll-formed in one of the materials in the table below. Brownbuilt is obtained from Global Roofing Solutions.

Material	Metal Grade	Colour One Side	Colour Two Side
Galvanised Z275	ISQ 300	_____	_____
Chromadek® Z200		✓	Special
Zincalume® AZ150	G300	_____	_____
Clean COLORBOND™ AZ150		✓	Special
ZincAL® AZ150	G300	_____	_____
COLORPLUS® AZ150		✓	Special
Aluminium Mill Finish	3004 or 9017	_____	_____
Color-Tek G4		✓	Special

Note

Brownbuilt is readily available in Galvanised steel and the following Chromadek® colours - Fish Eagle White, Dove Grey and Dark Dolphin. Other materials and colour coatings listed in the above table, are on enquiry only and may incur longer lead times.

The Profile

The profile shall have three standing ribs at 203mm centres giving a nett cover of 406mm. The rib height shall be 48mm and provide capillary breaks. Each pan shall incorporate two stiffener ribs.

Assembly

It is recommended that Brownbuilt sheeting be laid by an approved contractor in strict accordance with manufacturer's specifications. When using a GRS Approved Contractor, a five year guarantee of site-workmanship and water tightness can be issued after approval by Global Roofing Solutions.

Flashings

Stop endings must be formed at the apex and the pan turned down at the eaves to form a drip. The roof sheeting shall be closed as necessary with purpose made flashings of a design approved by the supplier. These flashings shall be notched around ribs where necessary and fixed on S1 clips. All these operations must be performed with special tools available from the supplier.

Site Handling

Brownbuilt sheets should be suitably supported clear of the ground under well ventilated cover, away from risk of damage by building operations, contact with cement, dust, lime and abrasive dust, until required to be installed.

Cleaning Up

The complete roof must be kept clean and free of any swarf and debris.

Quality Assurance

The manufacturer shall be assessed and certified as complying with ISO 9001:2015 Quality Management System.

Solar Clamp

Please refer to the GRS PV Clamp brochure.



Note

A GRS / Brownbuilt installation warranty will only be honoured if the GRS BB-PV Clamp is used when installing photovoltaic panels.



The Concealed Fixing Concept

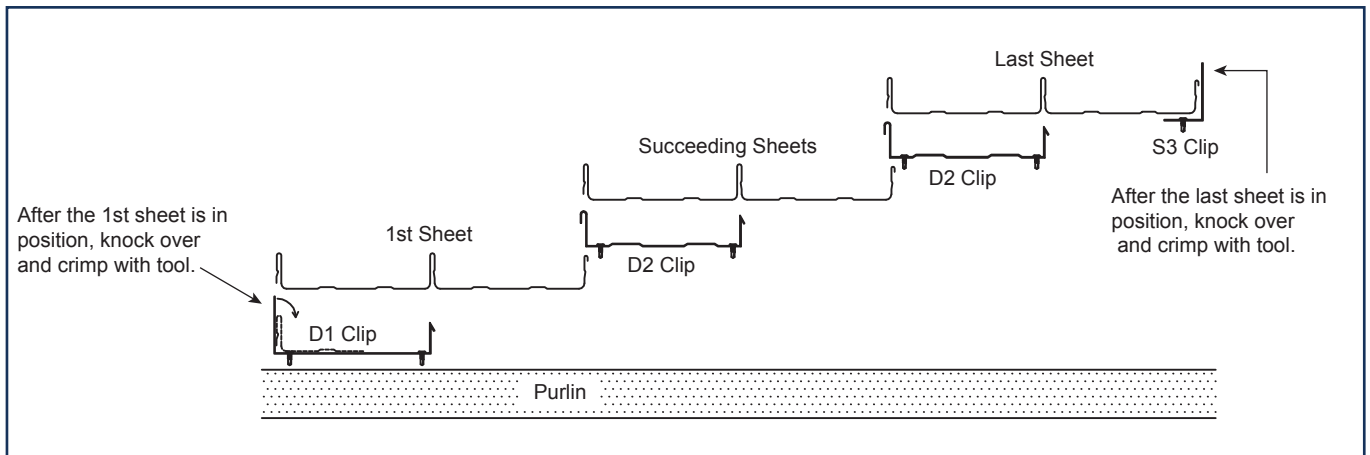

Fasteners

The recommended fasteners for fixing the clips to steel or timber purlins are as follows:

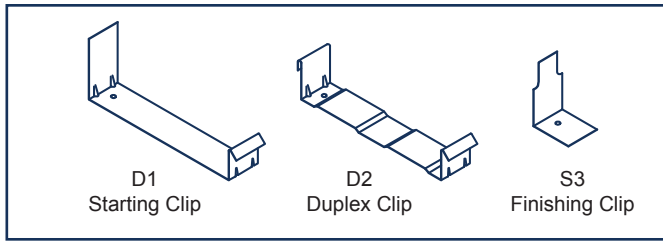

Where insulation is installed between purlin and sheeting, the length of screws should be increased depending on the compressed thickness and density of the insulation.

For Steel Purlins - At least 3 threads should protrude past the support.

For Timber Purlins - The screw should penetrate the purlin by the same depth recommended as if there is no insulation.

Note

Where screws exceed 45mm long, they should be No.12 with a PH3 head.

Steel Purlins - (1mm to 4,5mm thick)

No. 10 - 16 x 16mm long self-drilling Wafer head PH2 screws #3 drill point.

Steel Purlins - (5mm to 12.5mm thick)

No. 12 - 24 x 38mm long self-drilling Wafer head PH3 screws #5 drill point.

Timber Purlins

No. 10 - 11 x 45mm self-drilling Wafer head PH2 screws #17 drill point.

***For light steel frame purlins less than 1mm thick, please contact GRS.**

Brownbuilt™ sheeting as ceiling / underslung

Brownbuilt roofing is also used as an economical ceiling combination for canopies, shop verandahs, link corridors and suspended roofs.

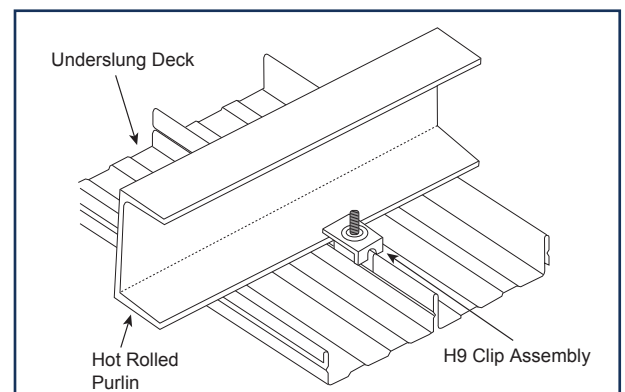
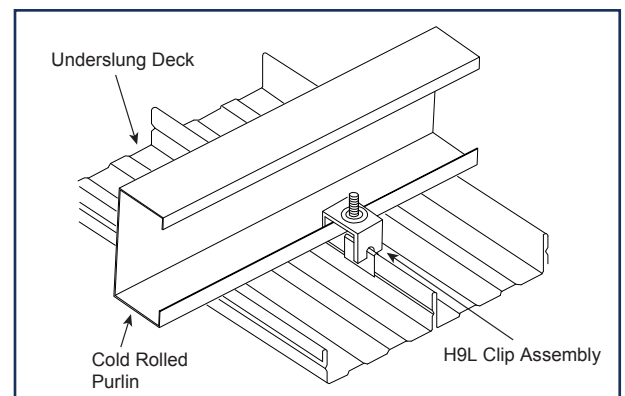

Note

Fasteners must be selected to match the life expectancy of the roofing and cladding material. The coating class for fasteners, complying with SANS 1273, should be used in conjunction with all roofing and cladding material. For a full range of compatible fasteners, please refer to the GRS Installation Manual.

Additional Applications

Sheet Lengths

Available ex-factory in sheet lengths limited only by transport restrictions, normal loads 12.5m and abnormal loads 18.6m. Longer lengths can be milled on site, obviating end laps which are not recommended on low pitch lengths.

End lapping negates the concealed fix concept and no water tightness guarantee can be given.

End lapping also reduces the life expectancy of the roof, due to corrosion.

Bullnosing and Cranking

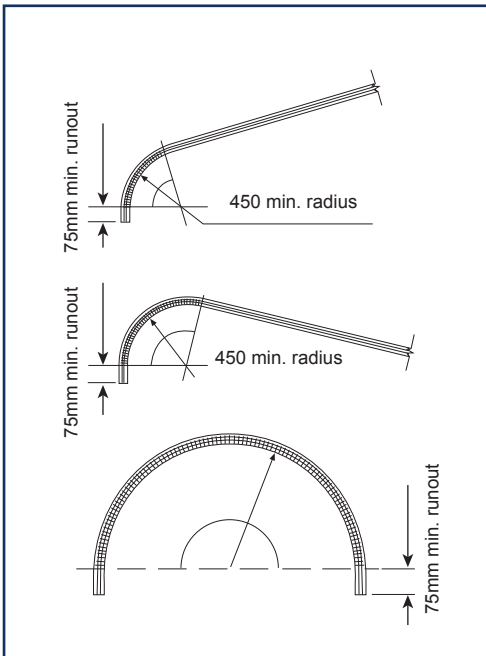

Note

Reverse cranking is not possible.

Rib Cap Detail

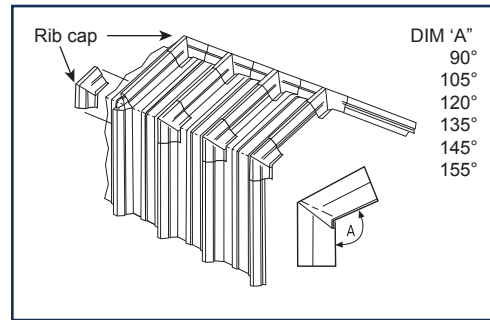

Curving

Brownbuilt can be crank curved (convex only) to any radius over 800mm by increasing the distance between the "cranking" indentations across the sheet.

Springing

Straight sheets may be sprung on site over a rounded structure with a minimum radius of 40 metres convex and concave, with internal spans for purlins at 1.5m maximum for convex and 1.3m maximum for concave.

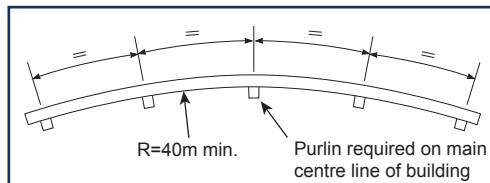

Note

Consideration for road transport has to be taken into account.

Refer to the GRS Installation Manual for detailed dimensions and fixing instructions.

Site cranking for milled sheets is available on application.

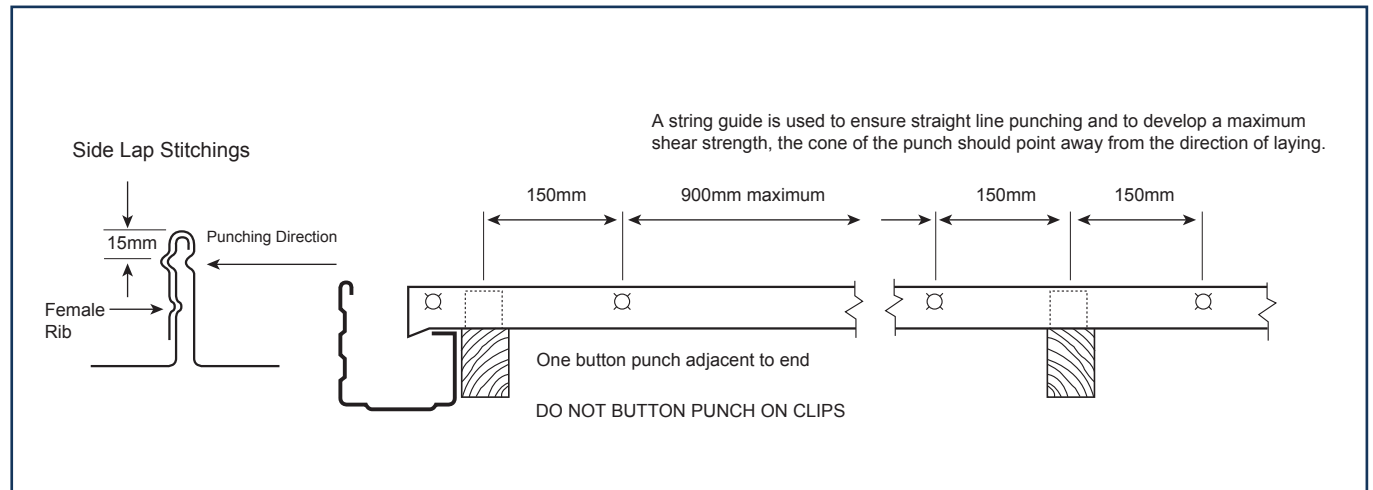

Profile: Brownbuilt™

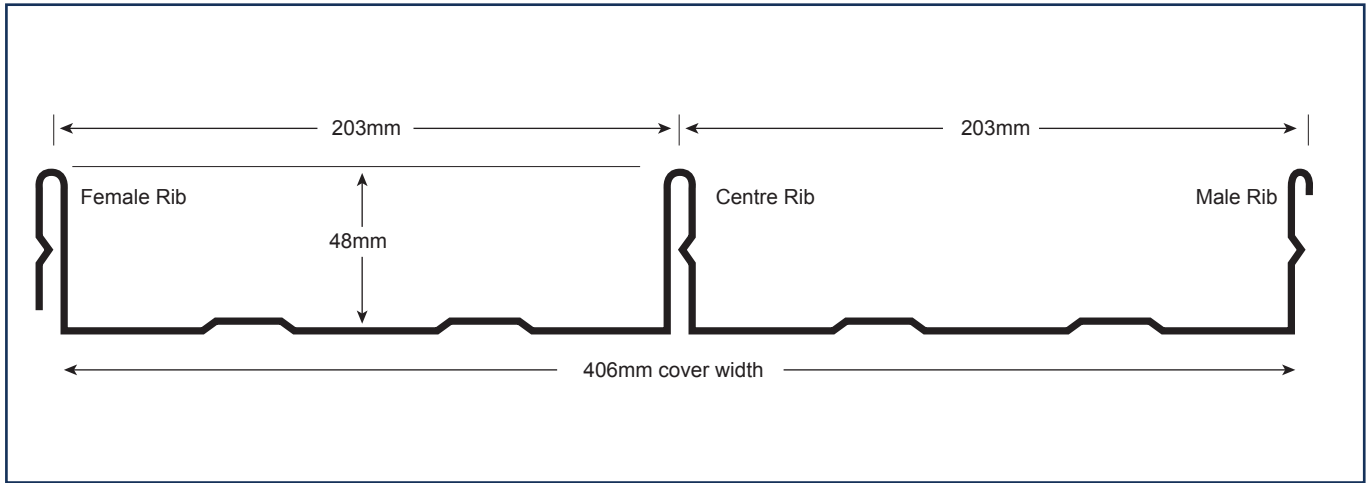

Load Span Table

The recommended purlin support centres are based on the following design criteria and obtained through testing:

	Ultimate Superimposed Distributed Load	Ultimate Uplift Load
ROOFS	1.50 kN/m ²	1.60 kN/m ²
WALLS	0.75 kN/m ²	

Note

At 1° slope, all roof supports must be in the same plane as slight variations can result in a zero or negative fall. This may even occur after completion of the building over time. Where possible it is wise to design for a minimum of 2° slope to ensure a positive fall.

Drainage Table

Maximum roof run (in metres) for roof slopes and rainfall intensities shown. These figures are based on unrestricted, free flow of water.

Brownbuilt Roof Slope	Rainfall Intensity mm/h				
	200	250	300	400	500
1°	205m	164m	137m	102m	99m
2°	276m	220m	184m	137m	110m
3°		268m	224m	167m	133m
5°			290m	218m	174m
7.5°				267m	214m
10°					249m

Maximum Allowable Support Spacings

Type of Span	0,58mm	0,8mm	0,8mm Aluminium	0,6mm Stainless Steel
Roofs				
Single Span	1.500m	2.400m	1.200m	1.500m
End Span	1.500m	2.400m	1.200m	1.500m
Internal Span	1.800m	2.700m	1.500m	1.800m
Cantilever (unstiffened)	0.200m	0.300m	0.100m	0.200m
Cantilever (stiffened- max. sheet length of 13m)	0.450m	0.600m	0.100m	0.450m
Walls				
Internal Span	2.700m	3.000m	1.500m	2.700m
Cantilever	0.400m	0.600m		
Nominal Mass kg/m ²	8.16	10.26	3.61	8.16

- Spans don't apply to natural sprung sheets. Consult GRS Technical Department.
- Spans for timber purlins to be in accordance with SANS 10400

Popular Flashings

Available in 0.58mm / 0.8mm thick galvanised Z275 steel, 0.53mm thick Zinalume® AZ150 or 0.55mm thick ZincAL® AZ150. Or with a colour option Chromadek® (Galvanised Z200), Clean COLORBOND™ (Zinalume® AZ150) or COLORPLUS® (ZincAL® AZ150) finish to one / two sides.

Flashings are also available in aluminium and stainless steel to match sheeting

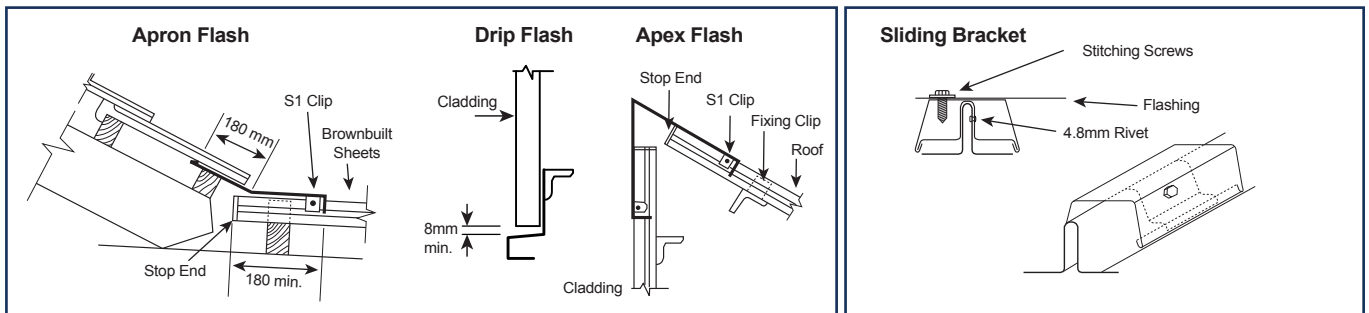
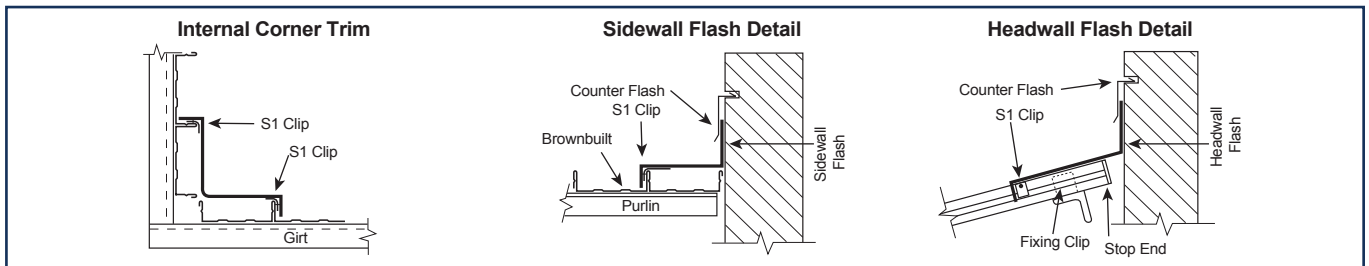
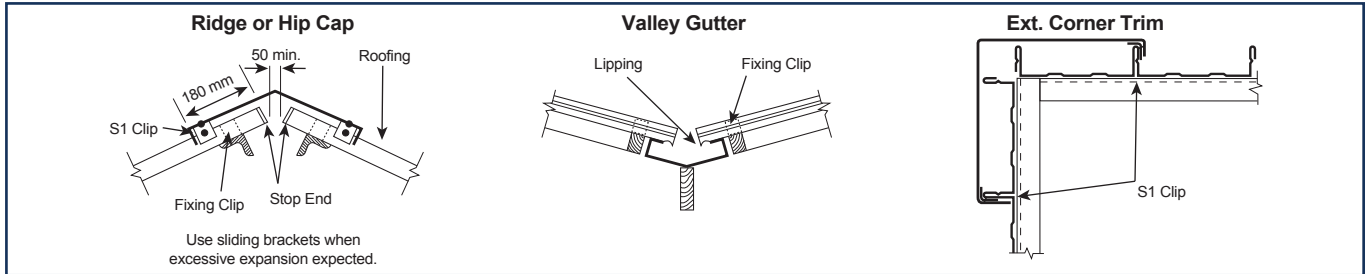

*** When sheet lengths are over 30m (20m for Aluminium) flashings must be fixed to sheets using sliding brackets.**

Tools

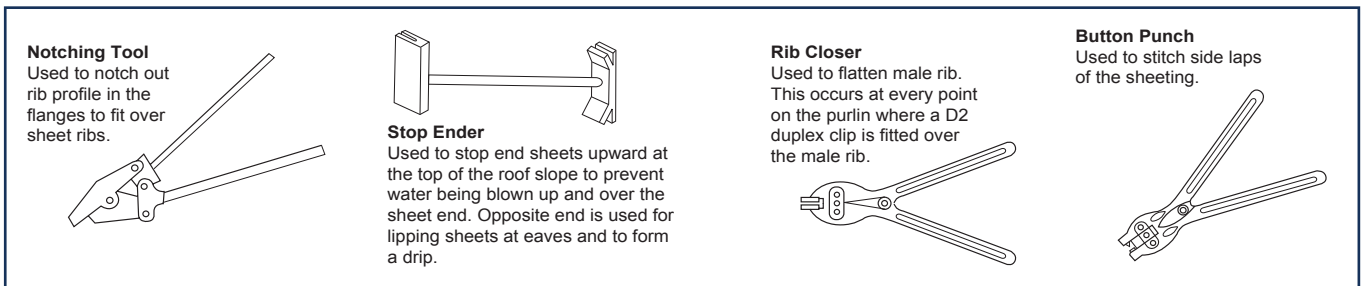

Please visit our website or contact GRS for standard flashing details

Isando Tel: +27 (0) 11 898 2900
Cape Town Tel: +27 (0) 21 521 1900
Durban Tel: +27 (0) 31 538 0940
Port Elizabeth Tel: +27 (0) 43 731 1826
East London Tel: +27 (0) 43 731 1826

Bloemfontein Tel: +27 (0) 51 432 3724
Nelspruit Tel: +27 (0) 13 492 0746/7
Polokwane Tel: +27 (0) 15 293 0313
Rustenburg Tel: +27 (0) 14 596 6121
Upington Tel: +27 (0) 54 332 1657

Exports Tel: +27 (0) 11 898 2900
Botswana Tel: +267 (002) 310 5761/2
Namibia Tel: +264 (002) 61 263 890



@GRSRoofs

e.&o.e

