

GRS Klip-Tite

Global Roofing Solutions Klip-Tite™

ROOFING LIKE NO OTHER



Talk to **THE SMART ROOF PEOPLE**
www.globalroofs.co.za
marketing@globalroofs.co.za



GRS Klip-Tite



Typical Specification

Materials

The roofing shall be Klip-Tite profile, roll-formed in continuous lengths in one of the materials in the table below. Klip-Tite is obtained from Global Roofing Solutions.

Material	Steel	Colour One Side	Colour Two Side
Galvanised Z275	ISQ 550	_____	_____
Chromadek® Z200		✓	Special
Zincalume® AZ150	G550	_____	_____
Clean COLORBOND™ AZ150		✓	Special
ZincAL® AZ150	G550	_____	_____
COLORPLUS® AZ150		✓	Special

The Profile

The profile roll-formed from certified steel complying with (select from steel column in above table). The profile shall have 4 trapezoidal ribs at 233mm centres giving a nett cover of 700mm. The male rib shall have spurs to ensure a positive double interlocking action at side-laps. Each pan shall incorporate transverse stiffener ribs.

Assembly

It is recommended that Klip-Tite sheeting be laid by an approved contractor in strict accordance with the manufacturer's specifications. When using a GRS Approved Contractor, a five year guarantee on site-workmanship and water tightness may be issued after approval by Global Roofing Solutions.

Flashings

Stop endings must be formed at the apex and the pan turned down at the eaves to form a drip. The roof sheeting shall be closed as necessary with purpose-made flashings of a design approved by the supplier. These flashings shall be notched around ribs where necessary and fixed on S10 clips. All these operations must be performed with special tools available from the supplier.

Site Handling

Klip-Tite sheets should be suitably supported clear of the ground, under well ventilated cover, away from risk of damage by building operations, contact with cement, dust, lime and abrasive dust, until required to be installed.

Cleaning Up

The complete roof must be kept clean and free of any swarf and debris.

Quality Assurance

The manufacturer shall be assessed and certified as complying with ISO 9001:2015 Quality Management System.

Solar Clamp

Please refer to GRS PV Clamp brochure.



Note

A GRS / Brownbuilt installation warranty will only be honoured if the GRS KT-PV Clamp is used when installing photovoltaic panels.



The Concealed Fixing Concept

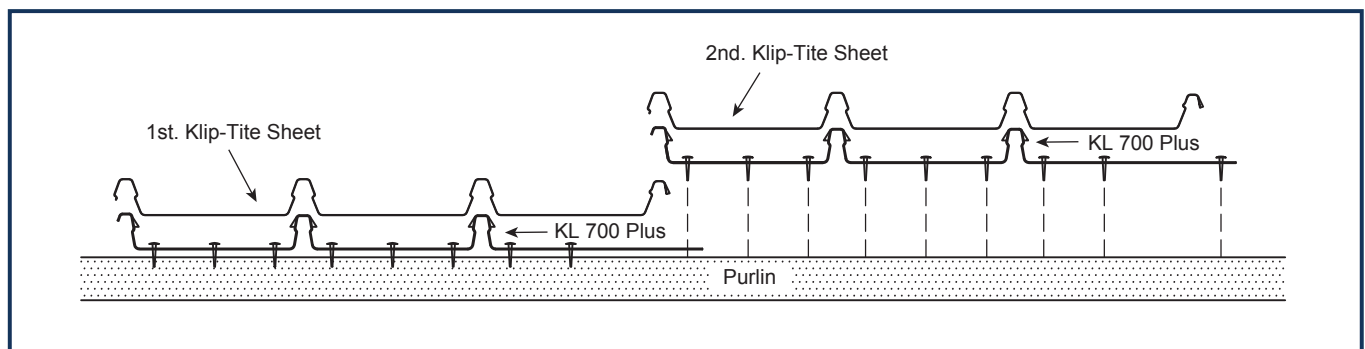
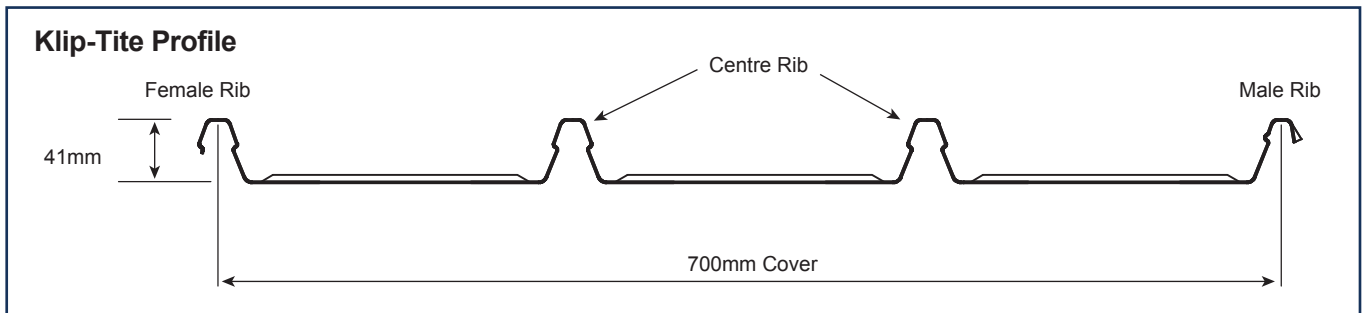

Fasteners

The recommended fasteners for fixing the KL 700 & KL 700 Plus clips to steel or timber purlins are as follows:

For Steel Purlins

At least 3 threads should protrude past the support.

1mm to 4,5mm thick

No.10 - 16 x 16mm long self-drilling Wafer head PH2 screws #3 drill point.

5mm to 12,5mm thick

No.12 - 24 x 38mm long self-drilling Wafer head PH3 screws #5 drill point.

For Timber Purlins

The screw should penetrate the purlin by the same depth recommended as if there were no insulation.

No.10 - 11 x 45mm long self-drilling Wafer head PH2 screws. Type 17 drill point.

Where insulation is installed

Between purlin and sheeting, the length of screws should be increased, depending on the compressed thickness and density of the insulation. Please refer to the GRS Installation Manual for additional information on insulation fixing details.

***For light steel frame purlins less than 1mm thick, please contact GRS.**

Note

Where screws exceed 45mm long, they should be No.12 with a PH3 head.



Note

Fasteners must be selected to match the life expectancy of the roofing and cladding material. The coating class for fasteners, complying with SANS 1273, should be used in conjunction with all roofing and cladding material. For a full range of compatible fasteners, please refer to the GRS Installation Manual.

Additional Applications

Sheet Lengths

Klip-Tite is available, ex-factory, in sheet lengths limited only by transport restrictions; normal loads 12.5m and abnormal loads 18.6m. Longer lengths can be milled on site, eliminating end laps which are not recommended.

End lapping negates the concealed fix concept and no water tightness guarantee can be given.

End lapping reduces the life expectancy of the roof, due to corrosion.

Rib Cap Detail

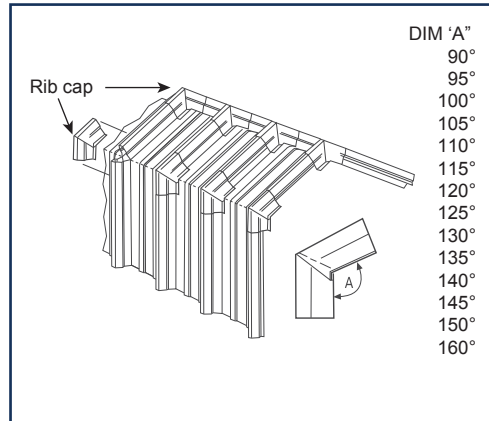

Bullnosing and Cranking

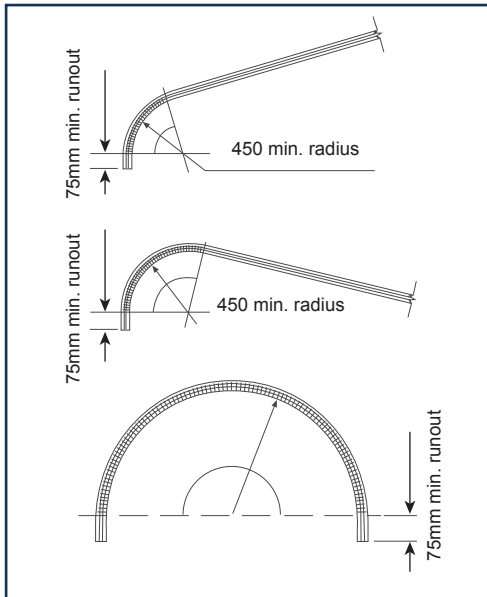

Note

Reverse cranking is not possible.

Curving

Klip-Tite can be crank curved (convex only) to any radius over 800mm by increasing the distance between the "cranking" indentations across the sheet.

Springing

Klip-Tite can be sprung to a minimum radius of 36m convex and 50m concave with internal span of purlin 1.5m maximum.

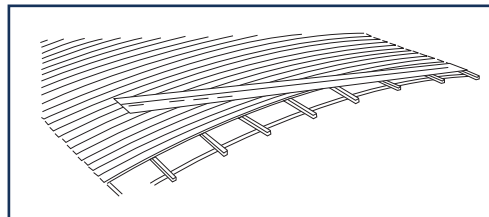

Note

Consideration for road transport has to be taken into account. Refer to the GRS Installation Manual for detailed dimensions and fixing instructions. Site cranking for milled sheets is available on application.

Insulation

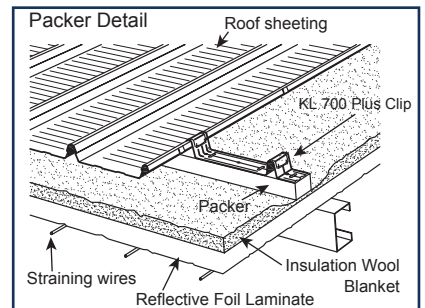
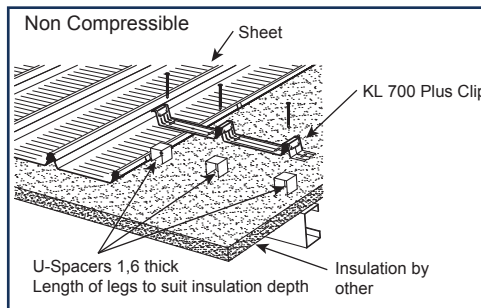
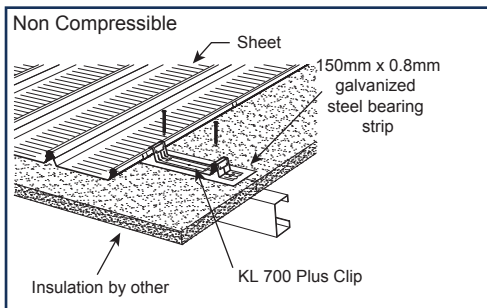

Note

Refer to installation manual for correct application for type of insulation, dependant on purlin centers, sheet lengths and torque setting of power tool used.



Profile: Klip-Tite™

Load Span Table

The recommended purlin support centres are based on the following design criteria and obtained through testing. Maximum loads are applicable if installed by an approved contractor:

Ultimate Superimposed Distributed Load		Ultimate Uplift Load
ROOFS	1.50 kN/m ²	3.20 kN/m ²

Note

At 1° slope, all roof supports must be in the same plane as slight variations can result in a zero or negative fall. This may even occur after completion of the building over time. Where possible it is wise to design for a minimum of 2° slope to ensure a positive fall.

Drainage Table

Maximum roof run (in metres) for roof slopes and rainfall intensities shown. These figures are based on unrestricted, free flow of water.

Klip-Tite Roof Slope	Rainfall Intensity mm/h				
	200	250	300	400	500
1°	150m	120m	100m	74m	60m
2°	201m	161m	134m	100m	80m
3°		196m	163m	122m	98m
5°			212m	159m	126m
7.5°				195m	156m
10°					182m

Maximum Allowable Support Spacings

Type of Span	0.47mm	0.5mm	0.53mm	0.55mm	0.58mm
Roofs					
Single Span	1.300m	1.400m	1.500m	1.800m	1.800m
End Span	1.600m	1.700m	1.900m	2.100m	2.100m
Internal Span	1.900m	2.000m	2.300m	2.500m	2.500m
Cantilever (unstiffened)	0.150m	0.180m	0.180m	0.200m	0.260m
Cantilever (stiffened- max. sheet length of 13m)	0.350m	0.400m	0.400m	0.450m	0.600m
Nominal Mass kg/m ²	5.1	5.5	5.7	5.75	6.6

Available in Galvanised, Zinalume®, Zinal® and Chromadek®, Colorbond™, Colorplus®

- Spans don't apply to natural sprung sheets. Consult GRS Technical Department.
- Spans for timber purlins to be in accordance with SANS 10400

Span Terminology

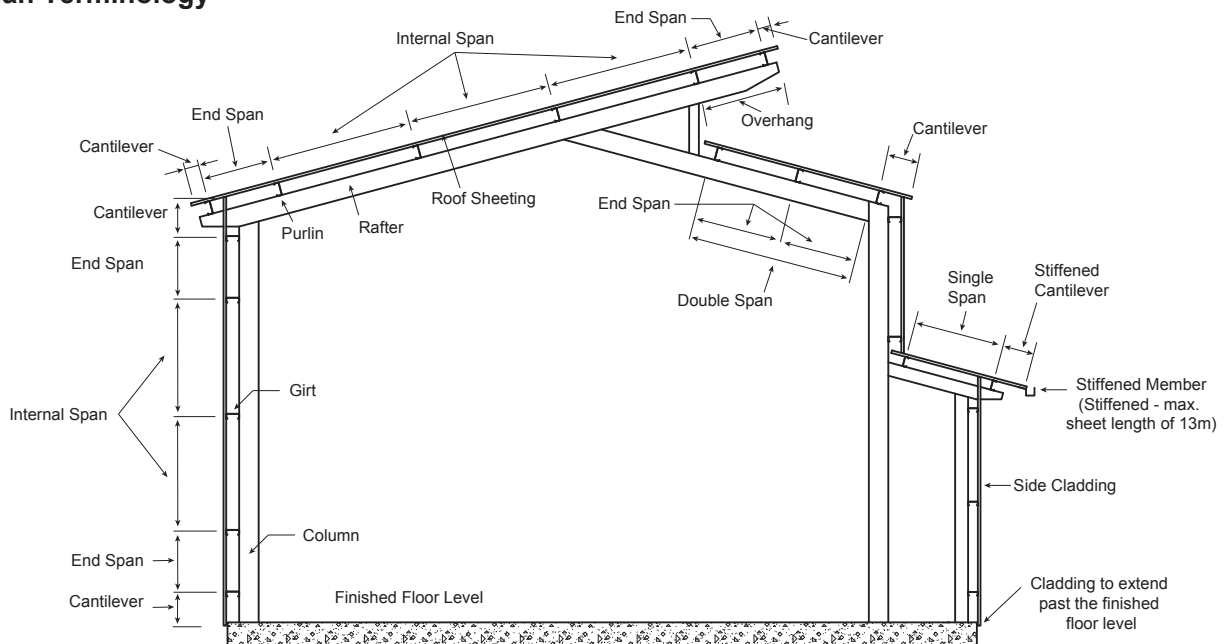

Popular Flashings

Available in 0.58mm / 0.8mm thick galvanised Z275 steel, 0.53mm thick Zinalume® AZ150 or 0.55mm thick ZincAL® AZ150. Or with a colour option Chromadek® (Galvanised Z200), Clean COLORBOND™ (Zinalume® AZ150) or COLORPLUS® (ZincAL® AZ150) finish to one / two sides.

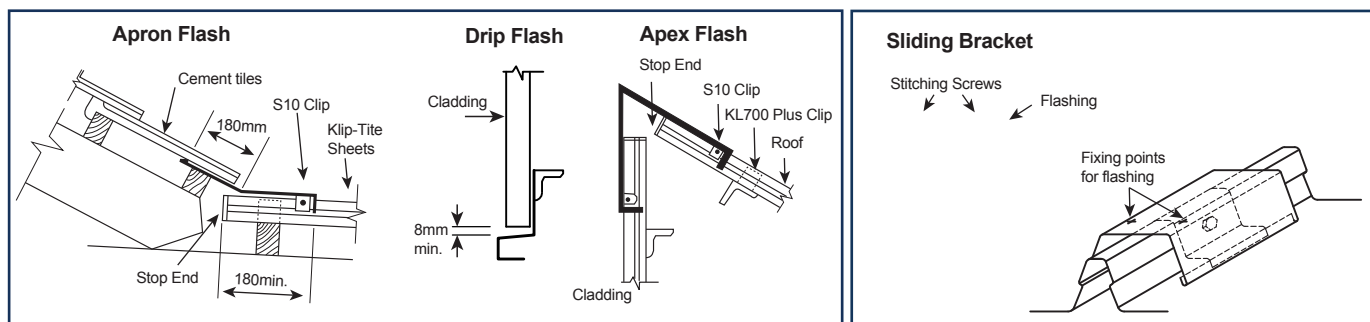
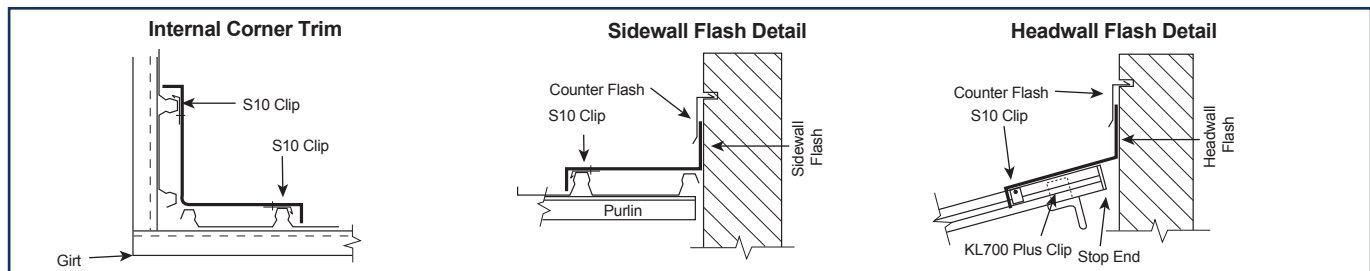
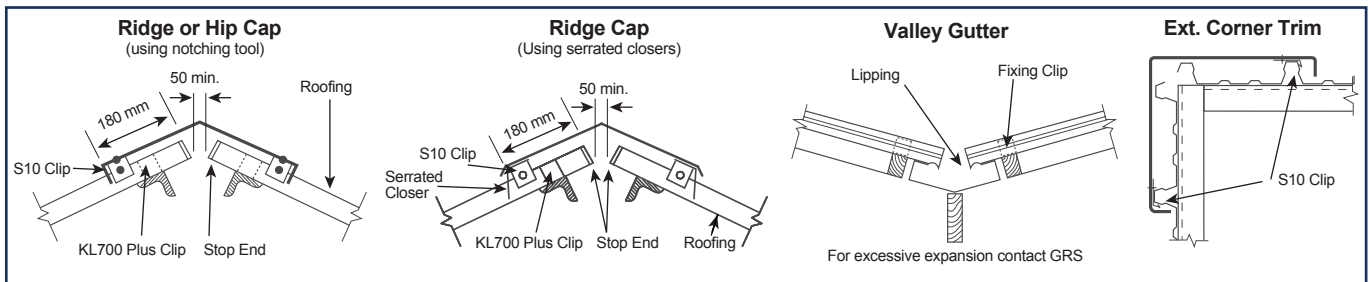

*** When sheet lengths are over 30m flashings must be fixed to sheets using sliding brackets.**

Tools

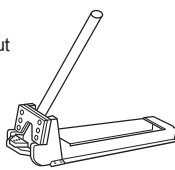
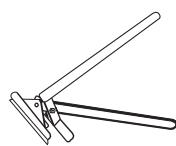
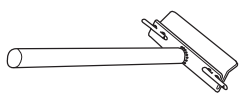
<p>Notching Tool Used to notch out sheet ribs profile in the flanges of flashings to fit over sheet ribs.</p> 	 <p>Turn-up Tool Used to stop end sheets upward at the top of the roof slope to prevent water blown up and over sheet end.</p>	 <p>Turn-down Tool Used to lip sheets downward at the eaves to prevent water flowing back on the underside of the sheets.</p>
---	---	--

Please visit our website or contact GRS for standard flashing details

Isando	Tel: +27 (0) 11 898 2900	Bloemfontein	Tel: +27 (0) 51 432 3724	Exports	Tel: +27 (0) 11 898 2900
Cape Town	Tel: +27 (0) 21 521 1900	Nelspruit	Tel: +27 (0) 13 492 0746/7	Botswana	Tel: +267 (002) 310 5761/2
Durban	Tel: +27 (0) 31 538 0940	Polokwane	Tel: +27 (0) 15 293 0313	Namibia	Tel: +264 (002) 61 263 890
Port Elizabeth	Tel: +27 (0) 43 731 1826	Rustenburg	Tel: +27 (0) 14 596 6121		
East London	Tel: +27 (0) 43 731 1826	Upington	Tel: +27 (0) 54 332 1657		



@GRSRoofs

e.&o.e