

INTRODUCTION



CORROSION TREATMENT AND POWDER COATING

All Trellidor Security Shutters are manufactured in an LPCB audited factory. The manufacturing process includes etching and pre-treatment for enhanced corrosion resistance before undergoing powder coating with a UV resistant polyester coating. This helps to retain the quality finish and increases the lifespan of the Trellidor Security Shutter, making them suitable for either internal or external installation in both coastal and inland conditions.

The Trellidor Quality Management System (QMS) has been certified to ISO 9001: 2015 by BRE-LPCB.

CONSTRUCTION MATERIALS

COMPONENT	MATERIAL
Frame	Structural grade Aluminium extrusions, of the 6063-T5 alloy.
Louvre	Structural grade Aluminium extrusions, of the 6063-T5 alloy.
Shutter side lock	Engineering polymer – glass filled Nylon 6/6
Rack and Pinion	Engineering polymer – glass filled Nylon 6/6
Reinforcing threaded bar	Anti-corrosion treated high tensile steel
Fasteners (Lock Nuts and Sleeve Nuts)	High tensile steel
Fasteners Rivets	Aluminium
	Marine grade Stainless Steel

EXPLODED VIEW

- ① Patented Trellidor locking system
- ② Internal threaded steel rod
- ③ Internal driving mechanism
- ④ Stainless steel hinges
- ⑤ Patented S-shaped louvres
- ⑥ Shutter side lock

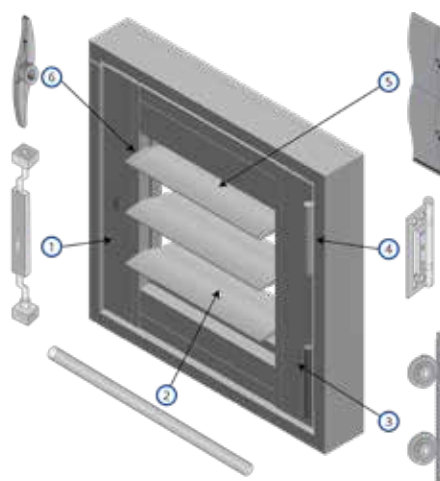

FEATURES & BENEFITS



LOCKING SYSTEM (TRELLILOK)

FEATURES	BENEFITS
Patented locking system.	Effectively overcomes the disadvantages found in off-the-shelf and DIY locking systems.
Tried and tested lock that is fitted to all Trellidor security barriers.	A reliable locking system that efficiently secures the shutter.
Choice of lock height position. Lock position cannot be higher than 200 mm from top of panel and not lower than 200mm from bottom of panel.	The keyhole and lock can be positioned at a height to suit unique/individual needs.

TRELLIDOR CYLINDER

FEATURES	BENEFITS
Anti-bump and anti-snap.	Effective counter measure to lock picking and / or snapping (breaking) of the cylinder.
Supplied with three keys per cylinder.	Alleviates the inconvenience of having to order keys for multiple persons.
Keys are available in two options, Random or Keyed alike in suites of 12.	The Keyed-Alike (matching) arrangement, allows one set of keys to be used on multiple product units thus minimising the risk associated with carrying/ managing too many keys.
Unique key code.	Reduces the risk of having unlawfully duplicated keys.

FEATURES & BENEFITS

SHUTTER SIDE LOCK

FEATURES	BENEFITS
Made from engineering polymer – Glass filled Nylon 6/6.	<ul style="list-style-type: none">• Hard wearing and maintenance free due to self-lubricating properties.• Eliminates metal to metal abrasion hence increased product durability.• Reduces friction, hence smooth operation of louvres.• Resistant to UV and as such will not discolour due to UV exposure.
Overlapping flanges.	Assist with the overall light and wind control of the shutter.
Integral louvre travel stops.	Louvres will not rotate past a predetermined fixed position, thus increased security.

DRIVE MECHANISM

FEATURES	BENEFITS
Patented concealed drive mechanism.	<ul style="list-style-type: none">• Reduces the risk of tampering.• Limited risk of finger entrapment when operating louvres.• Provides overall easy access for cleaning.• Makes the shutter look much neater because there are externally attached tilt rods.

THREADED BAR THROUGH EVERY LOUVRE

FEATURES	BENEFITS
Each louvre is reinforced by a 6mm threaded bar.	Increased resistance under attack, making the shutter difficult to breach.

CUSTOM STAINLESS STEEL HINGE

FEATURES	BENEFITS
Corrosion resistant. High load-bearing capabilities.	<ul style="list-style-type: none">• Reduced risk of sagging.• Increased security.• Maintenance free.• Increased product lifespan.

FEATURES & BENEFITS

LOUVRE

FEATURES	BENEFITS
Patented S-Shaped louvre profile.	<ul style="list-style-type: none">• Better water run-off.• Increased light block-out due to overlap.• Increased strength, thus increased security.

FINISHES

FEATURES	BENEFITS
UV resistant Polyester powder coating.	<ul style="list-style-type: none">• Resistant to scratching, chipping and wearing.• Easy to clean.• Resistant to UV and as such will not discolour due to exposure to UV.



All Trellidor products are finished in a state-of-the-art powder coating plant, as such the colours on this webpage will vary from the actual product colour. This is due to the difference in the way that light reflects off different mediums.

PROFILES / DIMENSIONS

REVEAL FIT

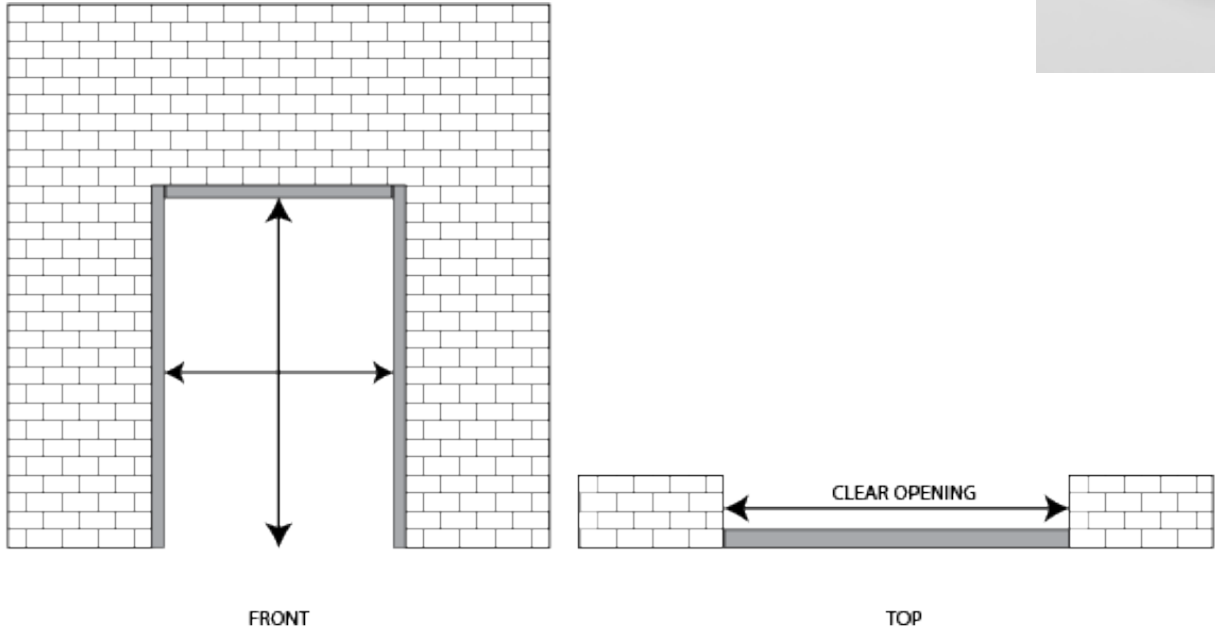

FACE-ON-FIT

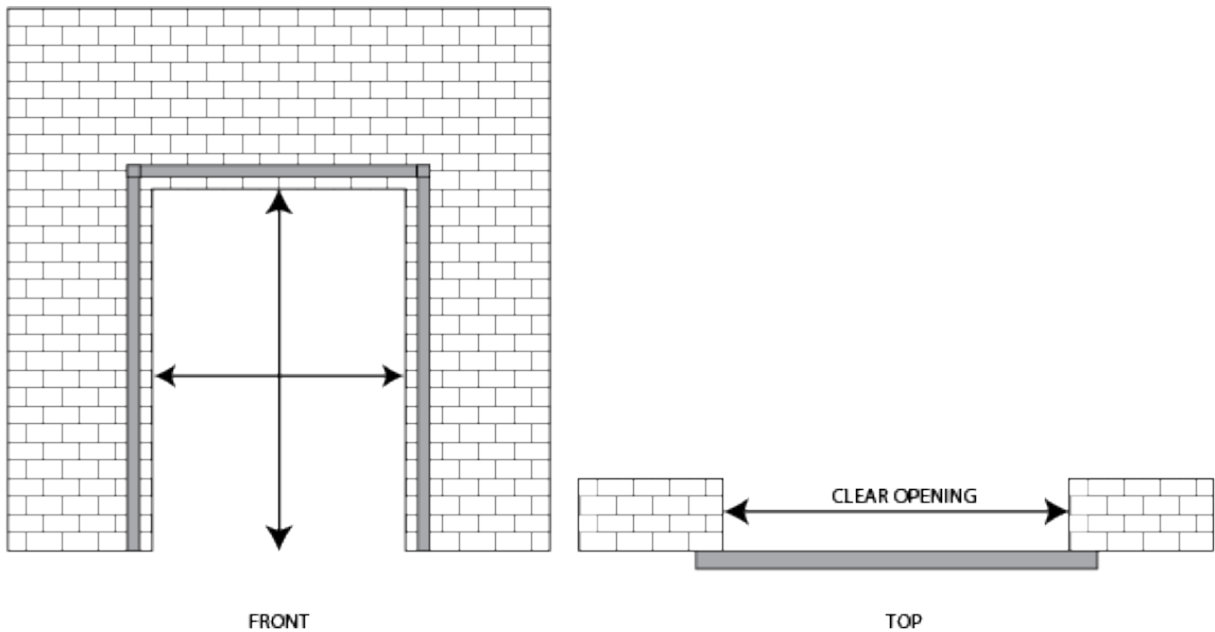

PROFILES / DIMENSIONS

PROFILE DIMENSIONS

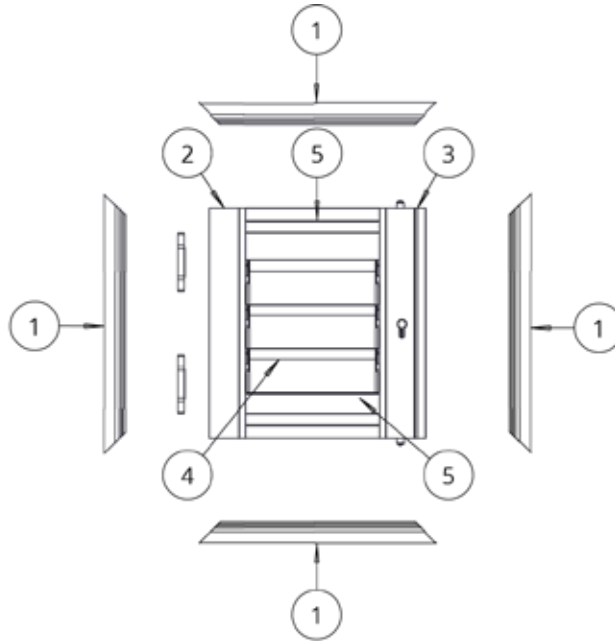

1

WINDOW FRAME
(OUTER FRAME)



2

40MM FRAME +
LOUVRE INNER SASH

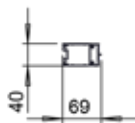

3

40MM FRAME WITH SHROUD
+ LOUVRE INNER SASH

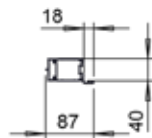

4

LOUVRE



5

INNER + OUTER
ADJUSTABLE FRAME

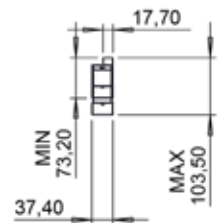

PROFILES / DIMENSIONS

INSTALLATION DOOR / WINDOW REVEAL FIT

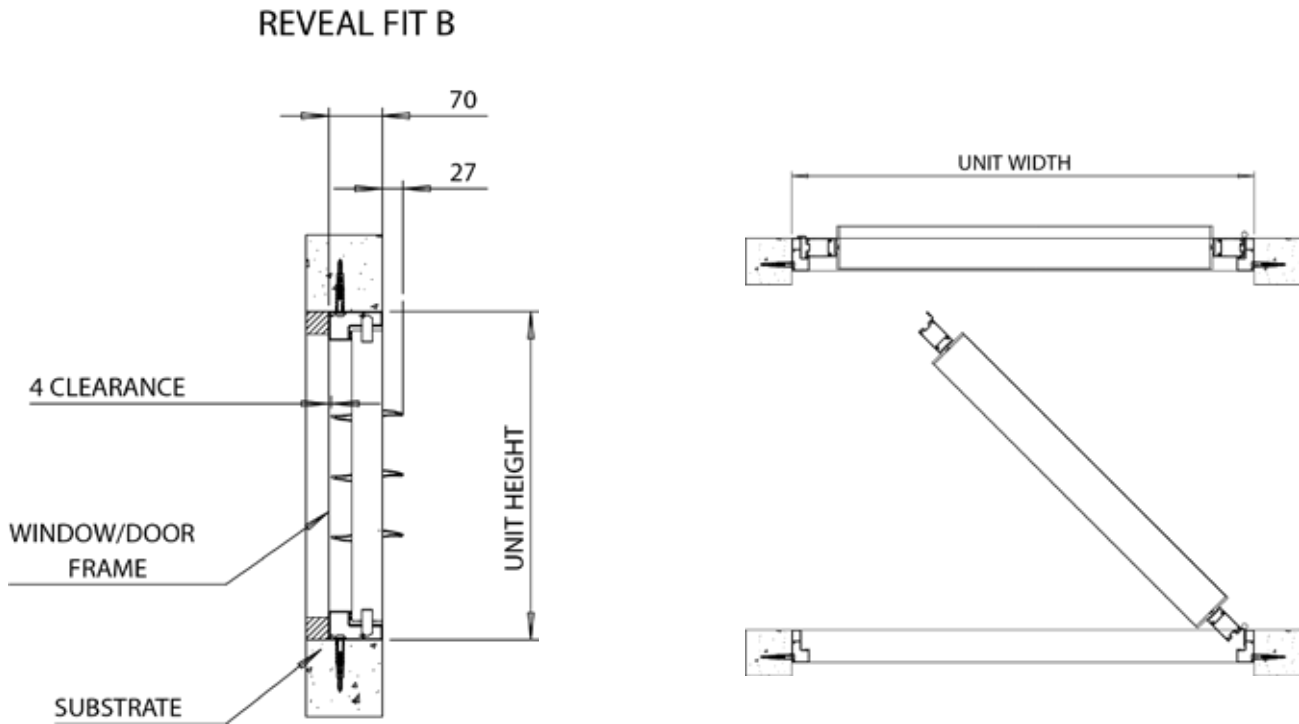

FACE-ON-FIT

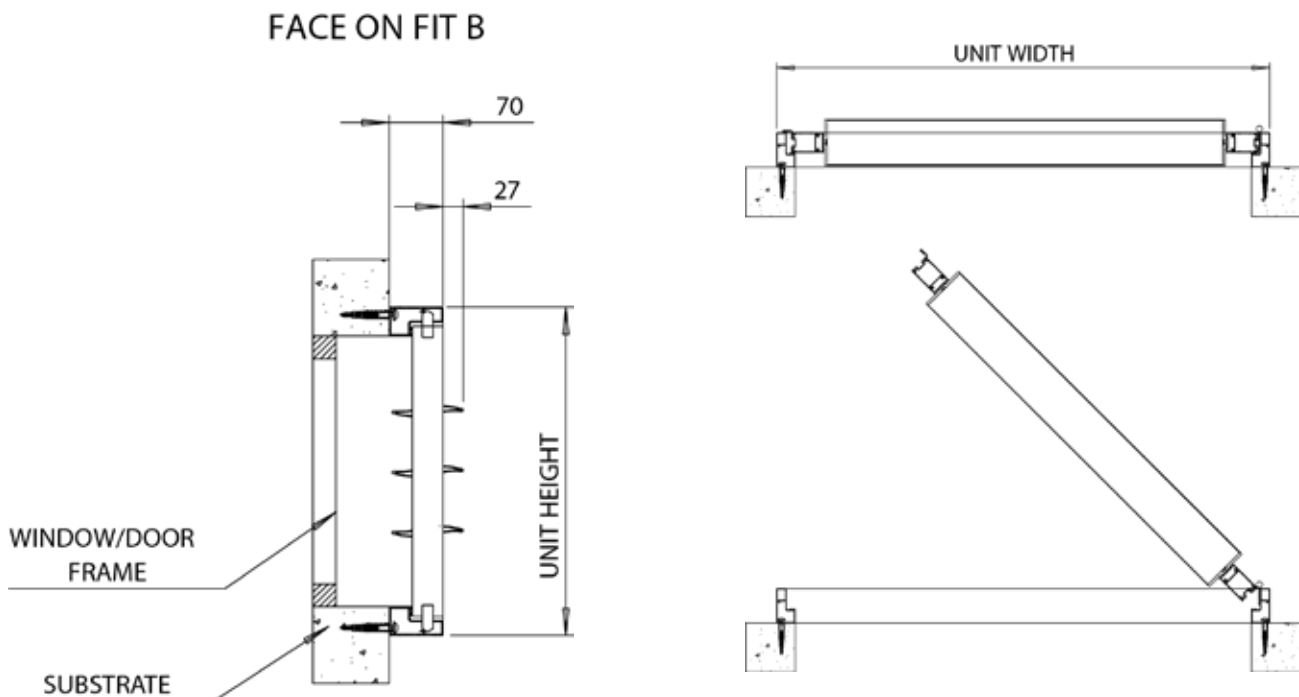

SIZE SPECIFICATIONS



MINIMUM / MAXIMUM SIZE LIMITS

		HEIGHT																													
From		400	405	505	605	705	805	905	1005	1105	1205	1305	1405	1505	1605	1705	1805	1905	2005	2105	2205	2305	2405	2505	2605	2705	2805	2905	3005	3105	3205
To		400	500	600	700	800	900	1000	1100	1200	1300	1400	1500	1600	1700	1800	1900	2000	2100	2200	2300	2400	2500	2600	2700	2800	2900	3000	3100	3200	3300
W I D T H	From	To																													
	300	300	*	*	*	*	*	*	*	*	*	*	*	*	*	*	*	*	*	*	*	*	*	*	*	*	*	*	*	*	*
	305	400	*	*	*	*	*	*	*	*	*	*	*	*	*	*	*	*	*	*	*	*	*	*	*	*	*	*	*	*	*
	405	500	*	*	*	*	*	*	*	*	*	*	*	*	*	*	*	*	*	*	*	*	*	*	*	*	*	*	*	*	*
	505	600	*	*	*	*	*	*	*	*	*	*	*	*	*	*	*	*	*	*	*	*	*	*	*	*	*	*	*	*	*
	605	700	*	*	*	*	*	*	*	*	*	*	*	*	*	*	*	*	*	*	*	*	*	*	*	*	*	*	*	*	*
	705	800	*	*	*	*	*	*	*	*	*	*	*	*	*	*	*	*	*	*	*	*	*	*	*	*	*	*	*	*	*
	805	900	*	*	*	*	*	*	*	*	*	*	*	*	*	*	*	*	*	*	*	*	*	*	*	*	*	*	*	*	*
	905	1000	*	*	*	*	*	*	*	*	*	*	*	*	*	*	*	*	*	*	*	*	*	*	*	*	*	*	*	*	*

OUT OF MAXIMUM LIMITS

NOTES

- Weight is 13kg/M2
- Minimum reveal required = 70mm
- For any unit height > 1200mm, the louvre operation will be split into 2 independently operated banks.
- Standard louvre split is 1200mm. Any other louvre split requirements must be put through as a special order.
- Louvre split cannot be higher than 200mm from the top of the panel and not lower than 200mm from the bottom of the panel.
- Cylinder operates anti-clockwise to lock.
- Cylinder punching (half/full) must be specified.
- The vertical centre line of the cylinder is positioned 63mm from the edge of outer frame of the unit.
- Special colours will attract a longer lead time and an additional cost.
- For 3 sided units, optional bristle strip is available on request.